



# SYSTEMHAUS TECHNIK

Your partner for cutting-edge research

# Our knowledge – your success

Benefit from our wealth of experience: we set standards and offer wide-ranging engineering expertise in an array of specialist disciplines, from mechanical and electrical engineering to CFRP and plastics technologies. Technical equipment or parts of a process can often be used in a completely different context. We know the available materials and technologies and have deep insight into their potential fields of application in scientific research. We put together an interdisciplinary working group for every project, made up of engineers, physicists, materials scientists, technicians, craftspeople, electronics specialists and production experts. In this way, we are able to develop fresh ideas with combined expertise from various fields and find the best possible solution together with our staff, some of whom have decades of experience. Drawing upon the knowledge of our experts enables you to achieve your objectives faster.

## Points of contact:

### Head of Department Systemhaus Technik

Andreas Bohle

Administration: Gabriele Heßing-Grimme

### Northern Region Systemhaus Technik

Regional Manager: Andreas Bohle

Head of Engineering: Marc Tegeler

Head of Operations Scheduling: Vanessa Rössler

Head of Production: Björn Köhnke

### Western Region Systemhaus Technik

Regional Manager: Markus Boje

Head of Engineering: Manfred Bunde

Head of Operations Scheduling: Thomas Riegler

Head of Production: Jens Lier

### Southern Region Systemhaus Technik

Regional Manager: Frank Müller (acting)

Head of Engineering: Matthias Lang

Head of Operations Scheduling: Frank Müller (acting)

Head of Production: Frank Müller



# Unique systems and processes for science and research

Are you looking for a process or high-tech instrument that is not yet available on the market? Our experts at Systemhaus Technik offer custom-made solutions. We design, develop and manufacture unique devices, systems and models for cutting-edge research, whether you are looking to develop a completely new solution, modify existing equipment or take your technology to the next stage. Since 1959, we have been developing concepts and instruments that are tailored to the visions, ideas and requirements of our clients. With more than 150 staff, we support research as advisors and partners.



“We consider ourselves as a partner for DLR’s institutes and facilities. Our aim to help their scientists achieve excellent results.”

Andreas Bohle  
Senior Head of Department  
Systemhaus Technik

Whether you need a feasibility analysis, concept study, simulation, prototyping, project management services or assistance with testing, we actively support your scientific endeavours at every stage of your project.



# EVERYTHING UNDER ONE ROOF

If we come up against the limits of commercially available manufacturing and testing technologies, we develop new methods that are capable of addressing the high demands of research.

We have been successfully creating highly complex, innovative instruments and systems for research for more than 60 years. We also provide long-term support and maintenance and are there for our partners throughout the entire product life cycle. We are able to do this because we offer all of our services under one roof – from planning, simulation and feasibility studies to development, production and assembly. We provide our clients with support during both early and late project phases. Our staff, who are adept at using the technologies and processes available in house, are the cornerstone of all this. Our experts know which processes and systems are available on the market and which need to be developed. They calculate the costs, understand how programmes are structured and can explore the technological potential. This promises our clients a high level of planning security and comprehensive support on their journey from an initial idea through to the end product.

Equipped with state-of-the-art specialist machinery and tools, we are able to process a wide range of materials, including special metals, ceramics, glass, CFRP and composites. Advanced measurement and testing procedures ensure that every instrument and system is produced and delivered with the optimum characteristics. Of course, we are certified in accordance with the DIN ISO 9001 standard and undergo regular quality assessments. Our systems meet all existing guidelines and requirements, and all of our projects are fully documented. We also evaluate and optimise our work processes through established quality management processes. Needs-based training and development ensure that our employees, in their capacity as technology innovators, will continue to meet the demands of our customers and partners in the future.

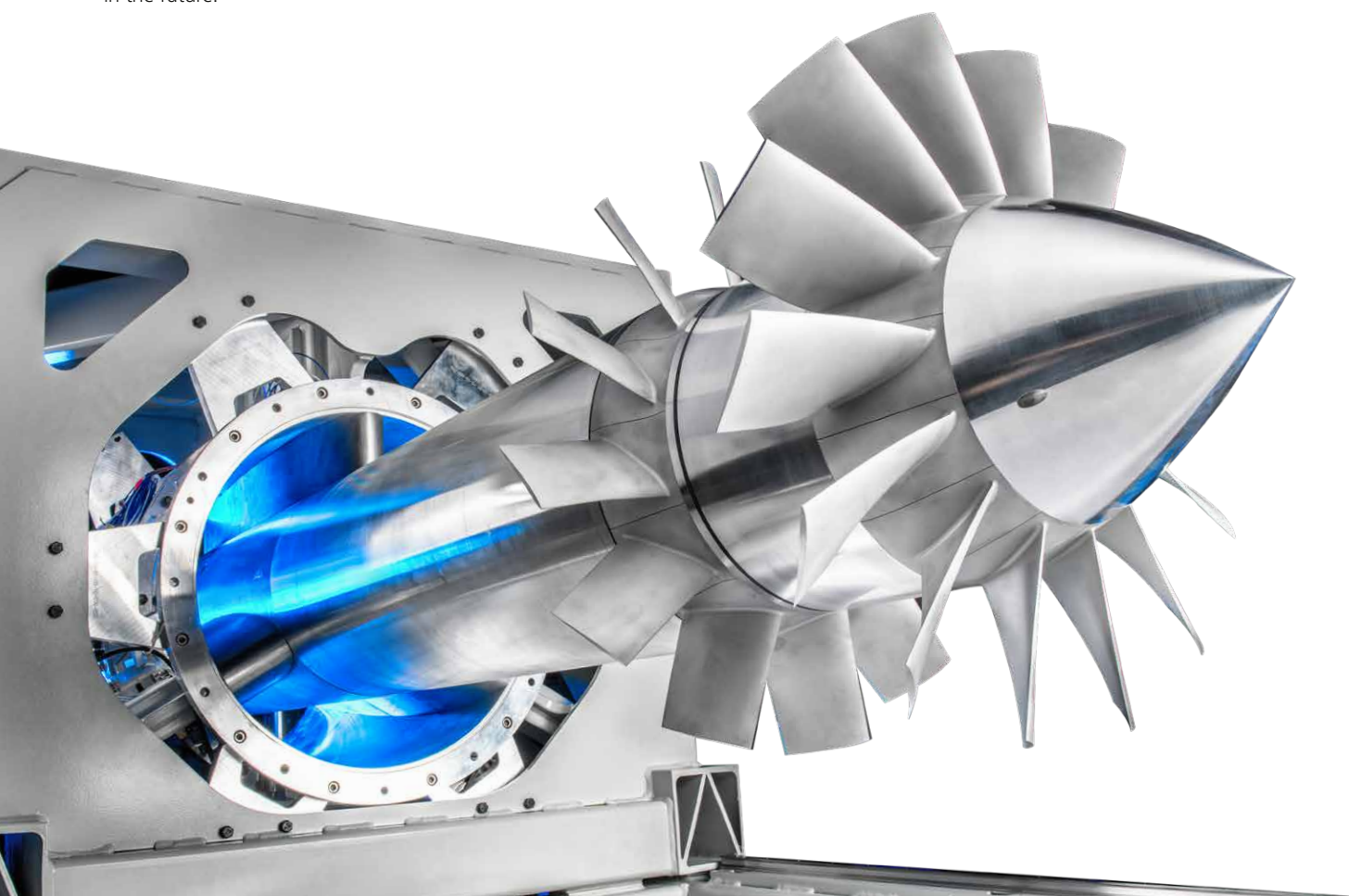

Fin stroke apparatus for conducting measurements in the Transonic Wind Tunnel, Göttingen (TWG)

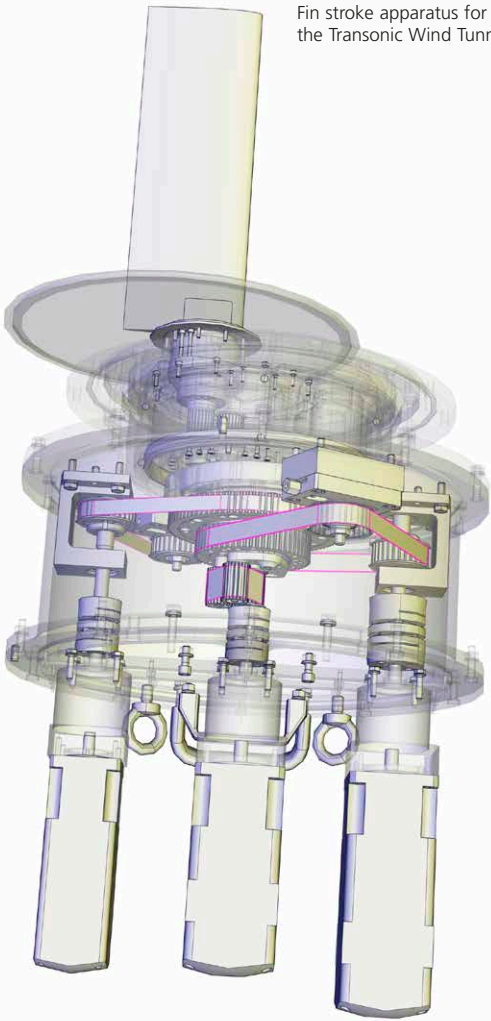

## ENGINEERING AT ITS BEST

We are committed to making the impossible possible. From a complex wind tunnel model made of exotic materials to test stands weighing several tonnes to be used for engine research, there are no limits to the inventiveness of our staff. Every project that is overseen and implemented by our personnel is different. The advantage of addressing ever-changing challenges is that the experience gained can be transferred from one project to another. By doing this, we have been able to provide highly complex, innovative instruments and systems for cutting-edge research for over 60 years and operate them successfully over the long term.

The project steps are always carried out in close cooperation with our customers, so changing requirements can also be considered at short notice. Our tightly knit network within Systemhaus Technik and with our external partners from industry and research ensures the best possible solutions are found. In this way, functional, technically flawless and highly reliable systems, instruments and models can be created from ideas that are often only roughly defined.

At Systemhaus Technik, solid engineering skills are accompanied by structured and certified management processes. The goals are highly effective systems, new processes or innovative materials that will help to open up future-oriented technologies and answer pressing questions in research.

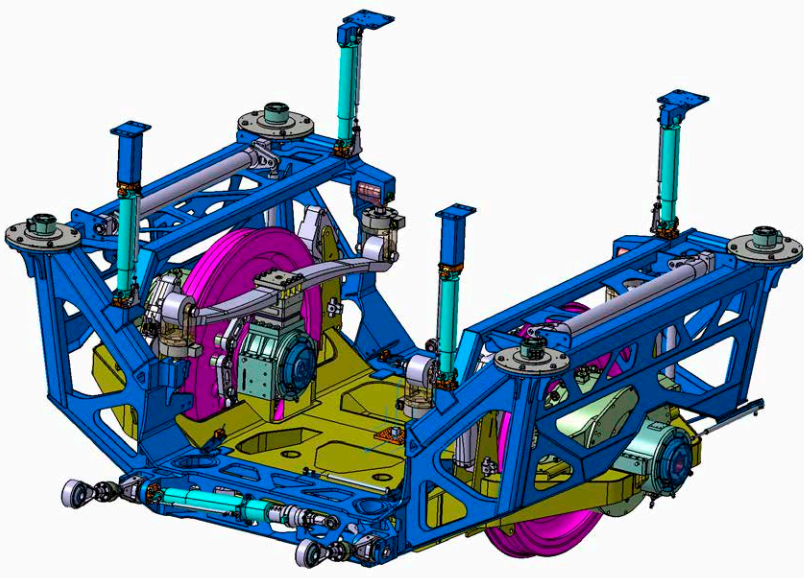

NGT-FuN chassis demonstrator

# COMPLEX MANUFACTURING TECHNOLOGIES

We have been making our unique expertise in manufacturing technologies available to researchers for decades. We join, connect and process almost all materials. Our experts are familiar with the properties of the individual materials and the technical possibilities for optimal manufacturing. This wealth of experience and in-depth knowledge of material properties also enables us to process special metals such as niobium, tantalum or tungsten, as well as ceramics.

We support our researchers in the implementation of complex manufacturing geometries, in the production of individual pieces and in conducting extensive load testing. For this purpose, we have a state-of-the-art machinery and tool inventory that can cope with unusual requirements. After all, the demands on instruments, materials and systems are usually more complex when deployed for the scientific community than when used on the usual industrial scale. That's why we are constantly developing existing technologies and processes.

For over 60 years, Systemhaus Technik has been providing innovative, reliable and one-of-a-kind products, delivered to our customers on time and with the high quality they expect.

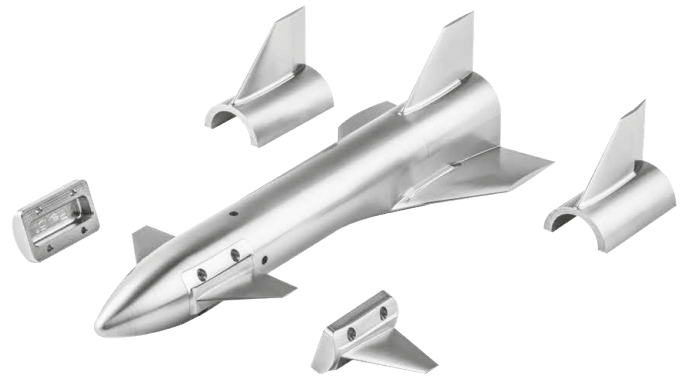

REFEX model

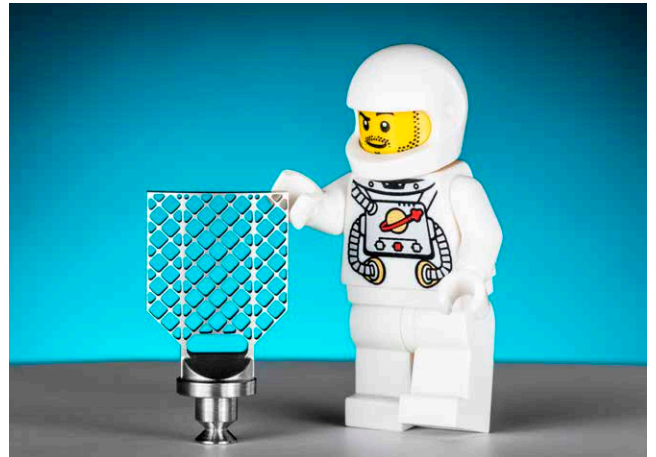

Grid fin



Modular inlet model



## Success milestones

- 1959 Founding of the first central design office and workshops
- 1982 Introduction of CNC technology (with punched tape)
- 1988 Introduction of CATIA V3 CAD system in the design office
- 1997 Introduction of wire electrical discharge machining technology
  
- 2006 Merger of the five sites to form Systemhaus Technik
- 2007 Upgrading of the machine inventory by introducing simultaneous 5-axis machining technology
- 2007 Introduction of a management system in accordance with ISO 9001
- 2009 Introduction of ultrasonic ceramic processing
  
- 2010 Introduction of metal 3D printing
- 2014 Introduction of risk assessments in accordance with the Industrial Safety Act and the Machinery Directive
- 2015 Development of computing expertise in relation to fibre-composite components
- 2016 Introduction of plastic 3D printing
- 2018 Production use of the 3DExperience database with CATIA V5
  
- 2020 Manufacture of ancillary medical equipment to combat COVID-19
- 2021 Requirements established for digital twins

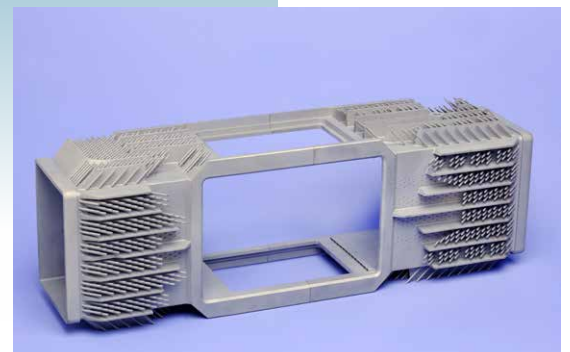

## **DLR at a glance**

DLR is the Federal Republic of Germany's research centre for aeronautics and space. We conduct research and development activities in the fields of aeronautics, space, energy, transport, security and digitalisation. The German Space Agency at DLR plans and implements the national space programme on behalf of the federal government. Two DLR project management agencies oversee funding programmes and support knowledge transfer.

Climate, mobility and technology are changing globally. DLR uses the expertise of its 55 research institutes and facilities to develop solutions to these challenges. Our 10,000 employees share a mission – to explore Earth and space and develop technologies for a sustainable future. In doing so, DLR contributes to strengthening Germany's position as a prime location for research and industry.

## **Imprint**

Publisher:

Deutsches Zentrum für Luft- und Raumfahrt e. V. | German Aerospace Center (DLR)

Dipl.-Ing. Andreas Bohle

Address:

Bunsenstraße 10

37073 Göttingen

Telephone: 0551 709 2210

E-mail: andreas.bohle@dlr.de

**DLR.de**

All images are property of DLR (CC-BY 3.0) unless otherwise stated.

Cover image: DLR



**Deutsches Zentrum  
DLR für Luft- und Raumfahrt**  
German Aerospace Center

Supported by:



Federal Ministry  
for Economic Affairs  
and Climate Action

on the basis of a decision  
by the German Bundestag