



# Research and Economic Development

2010/2011



**Published by** **Deutsches Zentrum  
für Luft- und Raumfahrt e.V.**  
in the Helmholtz Association

German Aerospace Center

**Address** Linder Höhe  
D-51147 Cologne

**Editor** Strategy and Alliances

**Design** CD Werbeagentur GmbH,  
Troisdorf

**Printing** Druckerei Thierbach GmbH,  
Mülheim/Ruhr

**Paper** Printed on:  
Contents – Circle matt white,  
100% recycled, Blue Angel  
certified with the EU Ecolabel

**Press date** Cologne, January 2012

**Reporting period** 1 July 2010 to 30 June 2011

**Data status** As at 31 December 2010

Reproduction in whole or in part  
or any other use is subject to  
prior permission from the German  
Aerospace Center (DLR).

[www.DLR.de/en/](http://www.DLR.de/en/)

Research and  
Economic Development  
2010/2011

German Aerospace Center (DLR)

# Contents

Preface .....	6
---------------	---

DLR at a Glance .....	8
-----------------------	---

## Research Report

<b>Aeronautics</b> .....	12
<b>Space</b> Space Administration, Space Research and Technology .....	22
<b>Transport</b> .....	32
<b>Energy</b> .....	40
<b>Security</b> .....	48
<b>Project Management Agency</b> .....	52



## Economic Development

<b>Future Development of DLR</b> .....	58
<b>Results</b> Third-Party Funding .....	59
Research-related Results .....	60
Technology Marketing .....	60
<b>Structure and Organisation</b> Development of the Research Center .....	64
Quality Management, Standardisation and Environmental Protection .....	67
<b>Partners</b> Helmholtz Association of German Research Centers (HGF) .....	72
National Networks .....	72
European Networks .....	74
European Groups .....	76
International Collaboration .....	80
Communications .....	86
Political and Economic Relations .....	86
<b>People</b> Gender Equality and Work-Life Balance .....	88
Human Resources Development .....	89
Human Resources Marketing .....	90
German Staff at ESA .....	91
<b>Commendations and Awards</b> .....	92

## Facts & Figures

### Members and Committees

Ex Officio Members .....	96
Sponsoring Members .....	96
Honorary Members .....	97
Scientific Members .....	97
Executive Board .....	97
Senate .....	98
Senate Committee .....	98
Space Committee .....	99
Scientific Technical Council .....	99

Affiliates and Joint Ventures .....	100
-------------------------------------	-----

Compilation of Performance Indicators .....	102
---	-----

Use of Funds.....	104
-------------------	-----

List of Abbreviations .....	105
-----------------------------	-----





# Preface

## **Dear Reader,**

Global challenges are also of central importance to DLR.

We are active in dealing with climate change, scarcity of resources, secure energy provision and sustainable mobility. However, we also contribute to areas such as communications, demographic development and health, as well as coping with various conflicts and recurrent catastrophes.

DLR has been extremely successful in its key research areas of aeronautics, space flight, energy, transport and security over the last year.



With the help of these topics – which are anchored in its strategy – DLR is well positioned for the future in its combined capacity as research institution, Space Agency and Project Management Agency.

In the first place my thanks goes to the employees, because DLR's success is dependent on their work and level of enthusiasm. This is how we secure the future. Together with professionalism and excellence DLR generates decisive competitive advantage, particularly in times of intense national and international competition.

The inventions and innovations that result from this contribute to strengthening Germany as a prime location. Our focal areas are presented in the "Research" section of this report.

At this point representative highlights from the long list of the past, very interesting DLR year are to be presented:

With our partners, we premiered the use of biofuels in regular flight operations. As well as the continued development of fuel cells, we are also making groundbreaking progress in their use, e.g. this year in our A320 ATRA as a source of electricity generation for an electrically driven nose wheel. Likewise, assuming control of the solar thermal tower power plant in Jülich was a highlight that has strengthened us for future tasks in this sector. By joining the "International Charter of Space and Major Disasters" we acknowledge global responsibility and DLR makes its competencies in Earth observation available to overcoming natural catastrophes. In recent months, DLR has inaugurated one of the world's most efficient aeroacoustic wind tunnels. With EU politicians visiting and the moderated "Master with Masters" exchange of ideas between NASA and DLR we have networked ourselves beyond national borders and increased our recognition.

In addition, DLR employees have made important contributions to the future of DLR in administrative areas and in the development of an attractive employer brand. The "Economic Development" section reports on the successful recognition of administrative work through the award of a prize.

Third-party business activities, personnel structure, the development of young talent, the quality assurance system and the management of a growing infrastructure form the focal areas of this section and are reinforced by the figures in "Facts & Figures" section.

To summarise, it can be said that DLR has experienced successful development again in 2010.

Please read all this in our current annual report. Thank you for your interest in DLR and I hope you enjoy reading along under the DLR motto: Knowledge for Tomorrow.

Yours,

Prof. Johann-Dietrich Wörner  
Chairman of the Executive Board





## DLR at a Glance

DLR is the national research center of the Federal Republic of Germany for aeronautics and space exploration. Its extensive research and development work in aeronautics, space exploration, transport and energy as well as security and defence is integrated into national and international cooperations. Beyond its own research, DLR as Space Agency also plans and implements German space exploration activities on behalf of the federal government. Furthermore, Germany's largest Project Management Agency is also part of DLR.

DLR employs approximately 6,900 people in 15 locations: Cologne (home to the Executive Board), Augsburg, Berlin, Bonn, Braunschweig, Bremen, Göttingen, Hamburg, Lampoldshausen, Neustrelitz, Oberpfaffenhofen, Stade, Stuttgart, Trauen and Weilheim. DLR also has offices in Brussels, Paris and Washington D.C.

DLR's mission comprises exploring the Earth and universe, research into environmental protection and technologies for a sustainable energy supply, and to increase environmentally-sustainable mobility, as well as communications and security and defence. DLR's research portfolio ranges from fundamental research to innovative development of the applications and products of tomorrow. In this way, DLR contributes the scientific and technical know-how that it has gained, thus enhancing Germany's industrial and technological reputation. DLR operates large-scale research facilities for its own projects and as a service provider for customers and partners. In addition, DLR supports young scientists and offers policy advisory services and is a driving force in the regions where it is represented.



**Locations**

- DLR Augsburg
- DLR Berlin
- DLR Bonn
- DLR Braunschweig
- DLR Bremen
- DLR Göttingen
- DLR Hamburg
- DLR Cologne
- DLR Lampoldshausen
- DLR Neustrelitz
- DLR Oberpfaffenhofen
- DLR Stade
- DLR Stuttgart
- DLR Trauen
- DLR Weilheim

**Institutes and Facilities**

- Aerodynamics and Flow Technology
- Aeroelasticity
- Propulsion Technology
- Structures and Design
- Vehicle Concepts
- Composite Structures and Adaptive Systems
- Flight Guidance
- Air Transport and Airport Research
- Flight Systems
- Microwaves and Radar
- Communication and Navigation
- Aerospace Medicine
- Material Physics in Space
- Remote Sensing Technology
- Atmospheric Physics
- Planetary Research
- Space Propulsion
- Space Systems
- Robotics and Mechatronics
- Solar Research
- Technical Physics
- Technical Thermodynamics
- Combustion Technology
- Transport Research
- Transportation Systems
- Materials Research
- German Remote Sensing Data Center (DFD)
- DLR Air Transportation Systems
- DLR Space Operations and Astronaut Training
- DLR Simulation and Software Technology







# RESEARCH REPORT



# Aeronautics

In aeronautics research, the last year was mainly characterised by setting a clear course for the next EU Framework Programme for Research. As the successor to the 7th Framework Programme for Research, this "Horizon 2020" Framework Programme will cover the years 2014 to 2020. If European aeronautics research until now has been predominantly in the general direction of "Research", aeronautics research topics will be arranged in future between Directorates-General of "Mobility and Transport" (DG MOVE) and "Research and Innovation" (DG RTD). This tendency to increasingly support innovation and thus close the partially existing gap between research and industrial application

is also demonstrated on a national level in the formulated high-tech strategy. DLR is facing this development by increasing its activities in industrial cooperation and innovation projects.

As a basis for the thematic orientation of aeronautics research in "Horizon 2020", "Flightpath 2050" was developed, a new vision for aeronautics that serves as a successor to ACARE "Vision 2020". "Flightpath 2050" was developed by a high-level group of experts, which was put together by the European Commission for this sole purpose and of which the Chairman of DLR Executive Board, Prof. Wörner was also a member. Five overarching challenges for aeronautics research were defined in "Flightpath 2050", the implementation of which is to be planned and monitored by a successor organisation to ACARE. Accordingly, the first meeting of "New ACARE" took place on the occasion of the Paris Air Show 2011 in Le Bourget.

During the period of this report DLR was also successfully involved in national and European research programmes, particularly in the German Aeronautics Research Programme IV (LuFo) and the EU's 7th EU Framework Programme for Research. As part of the European SESAR programme (Single European Sky ATM Research) it succeeded in achieving the status of an "Associate Partner" as a consortium with NLR.

## CFC-New Generation Fuselage

### Project with industrial workshop completed

Safer, cheaper and more comfortable flying: these are the goals set by the four DLR institutes in the CFC New Generation (NG) Fuselage project. After four years the project with advances in all areas was recently concluded with a joint industry workshop. Huge advances were made in the field of passenger safety and particularly new fire protection and damage tolerant resin systems were thus developed and tested. In addition, new crash concepts and robust hybrid components were developed. DLR now also has a suitable answer in case of damage: it can be detected with advanced structural health monitoring and fixed using an automatic repair process.

During a flight, acoustics have a direct influence on the well-being and thus the comfort of the passengers. In the project, both innovative passive noise absorption materials and active noise-reducing measures that could be directly integrated into the aircraft skin were investigated. Faster and more efficient technologies were developed to reduce costs.

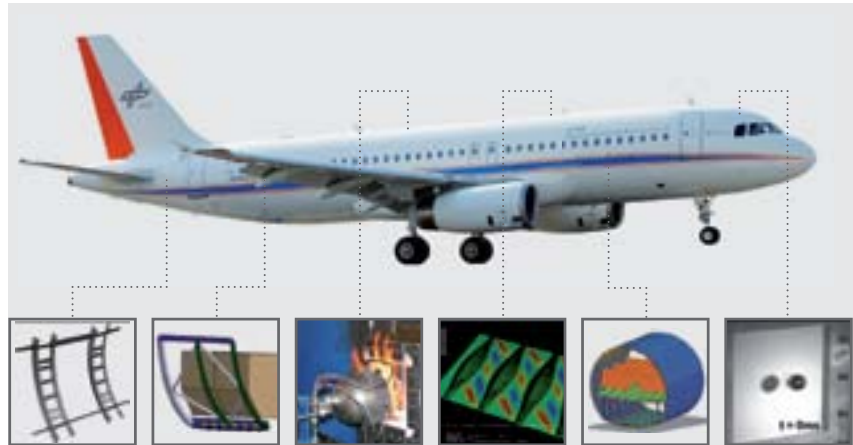

Examples of architecture concepts and investigations from CFC New Generation Fuselage project

It is possible to reduce the preforming process step by a factor of 30 with the help of inductive preforming. Fast resin systems were identified and tested for implementation in large-scale series production. With the help of a microwave autoclave it is possible to harden the components in half the time and using less energy. The overall reduction in aircraft costs was evaluated for a large number of developed technologies and important factors herein identified using scenario analyses.



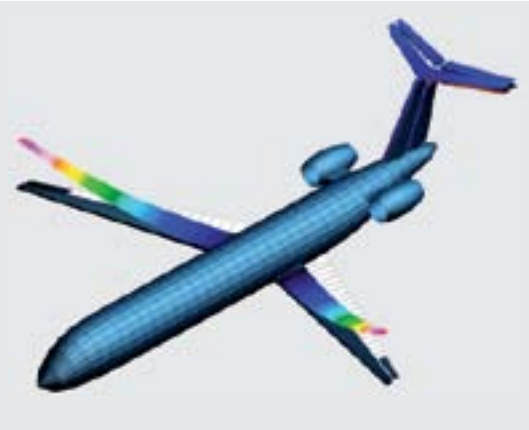

Aeroelastic model for the design of a configuration for 150 passengers with forward-sweeping wings

## Wake Vortices during Cruising Altitude

### Measurement of wake vortices at high altitudes

When aircraft are in flight, air turbulence is created behind them. These are known as wake vortices and can affect subsequent aircraft traffic. The German Aerospace Center has trialled a method for measuring wake vortices at high altitude with flight experiments using the DLR Falcon 20E research aircraft. It is particularly important for the assessment of wake vortices during commercial flights that the strength and intensity of the wake as well as the associated behaviour of aircraft flying into wake vortices can be measured in the air. As commercial flights take place at altitudes of over 10 kilometres, typical ground-level analysis is not possible.

In north-east German airspace flight experiments were flown through the wake vortices of typical passenger aircraft as centrally and often as possible. This is a very complex venture that places intense physical demands on the experiment teams and the test aircraft. A precondition was good teamwork between all partners involved: the DLR Institutes of Flight Systems and Atmospheric Physics, Deutsche Flugsicherung (DFS) and airline

pilots. Over 200 flights into wake vortices were flown in an area of between 5 and 25 nautical miles behind the passenger aircraft. The data gathered provides valuable knowledge regarding wake physics, flight dynamics and stresses that occur on the aircraft flying into the wake vortices.

## VAMP

### Preliminary design for passenger aircraft in association with DLR institutes

DLR explores technologies that are expected to significantly increase efficiency in future aircraft. The VAMP (Virtual Aircraft Multidisciplinary Analysis and Design Processes) project aims to realise the capacity of the preliminary design of passenger aircraft through intelligent cooperation with DLR institutes.

To this end a numerical design system is to be created by networking the disciplinary analytical tools available in DLR. As these also serve to develop new technologies, the costs of realistic depiction of new technologies are minimised in the preliminary design. The decentralised design system is based on the DLR CPACS (Common Parametric Aircraft Configuration Schema) data model, through which a high level of recyclability for software components and flexibility in the adaptation of the design system are achieved.

The system has already been successfully implemented in the subsequent design of a short-distance configuration. Through effective interaction of various experts from nine DLR institutes it has been possible to assess the results of the analyses (some of which are incredibly detailed) both individually and with regard to their interaction, and thereby demonstrate a good level of conformity with the reference data.



As well as special numerical processes, DLR has strengthened its cooperation processes in order to also have complex and unconventional aeronautics systems reliably available. An advanced approach to knowledge is the basis for relevantly linking DLR's competencies and future short-distance configurations.

There is close cooperation with other projects such as LamAiR, iGREEN, EVITA, ECCO and CATS. VAMP is thus realising a central contribution to DLR's virtual integration platforms (VIP), which expand the structured cooperation to the entire transport system.

## Low-Speed Wind Tunnel

### **The world's most efficient aeroacoustic wind tunnel in Braunschweig**

In order for DLR to assess the influence on noise reduction achieved by new technologies in aerodynamics, the world's most efficient aeroacoustic wind tunnel has been created in Braunschweig. The Low-Speed Wind Tunnel (LSWT) operated at Braunschweig Research Airport in the German-Dutch Wind Tunnels (DNW) Association has been renovated to this end. With its integration into the existing infrastructure for aeroacoustic research based on numerical simulations and flight experiments, aeronautics research now has at its disposal a unique environment for developing new forecasting models in the field of acoustics and technology to reduce aircraft noise.

The project was implemented by DNW and commissioned by the DLR Institute of Aerodynamics and Flow Technology. General planning and technical design were realised by DNW's own builders.

The design work was supported by the federal state of Lower Saxony, Airbus and the C<sup>2</sup>A<sup>2</sup>S<sup>2</sup>E Simulation Center, which was established by DLR. By using this, it is now possible to design such equipment numerically and without prior model tests for the first time. The new facility could therefore be finished in October 2010 after just a one-year planning phase and inaugurated on 02.12.2010 in the presence of the Minister President of Lower Saxony, David McAllister, and other representatives.

The LSWT is now one of the quietest wind tunnels and simultaneously has excellent aerodynamic properties and exceptionally high flexibility in terms of applications. There is even potential for further noise-reduction measures. As the world's only aeroacoustic wind tunnel the LSWT fulfils the conditions for investigations into aircraft noise on take-off and landing, and even for cruise configuration, which has the lowest acoustic signature. With the establishment of the Aeroacoustic Test Center in Braunschweig DLR will be in a position to conduct highly accurate aeroacoustic validation experiments that are urgently needed for the development of its computational aeroacoustic codes. This experimental facility is therefore of real importance for DLR's theoretical and numerical noise research.



Minister President McAllister at the inauguration of the Low-Speed Wind Tunnel in Braunschweig



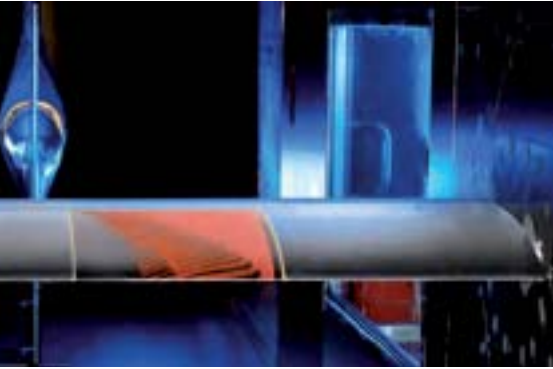

Rotor blade profile model EDI-M109 with hot-film sensors to evaluate the laminar-turbulent boundary-layer transition in the wind tunnel

## INROS/SHANEL

### Development of a rotor blade profile for more efficient helicopters

The profile currently used in helicopter rotors made by Eurocopter was developed by ONERA and DLR in the 1990s. The essential design goals were good flight performance and minimal moment coefficients under stationary flow conditions. The behaviour of the profile under non-stationary conditions could not be taken into account at that time due to insufficiently suitable numerical processes. Modern CFD processes allow non-stationary simulation of an oscillating profile section taking into account both viscosity and the full simulation of the rotor in forward flight in viscous flow. Tools are thus available that leave clear expectations in steps in the direction of improved rotor blade profiles.

Building on the capacity of these modern CFD processes, a design method was developed at DLR in close cooperation with the University of Stuttgart and Eurocopter Deutschland that takes into account the non-stationary behaviour of the profiles. With the help of this method, two new rotor profiles (EDI-M109 and EDI-MD112) were designed and optimised with 9 per cent and 12 per cent relative thickness as part of LuFO's INROS and SHANEL projects. The targeted improvements are related to aerodynamic performance, such as glide ratio, resistance and maximum lift, but particularly to the non-stationary behaviour of the profiles and thus in particular on the non-stationary dynamic stall and the development of the moment coefficients over the entire blade revolution.

The experimental validation of the new rotor blade profiles was a result of non-stationary measurements of the aerodynamic coefficients and the pressure distribution and the laminar-turbulent boundary-layer transition on CFC profile models with periodic oscillation in the transonic wind tunnel in Göttingen (DNW-TWG).



DLR FHS helicopter with a UAV

## MUM-T

### Safety concept for teaming manned and unmanned aerial vehicles

In order to increase the mission efficiency of the German Army Air Corps and, at the same time, minimise the threat to its own forces, the need for "networked cooperation between manned and unmanned aerial vehicles" was established in 2007. To this end, suitable unmanned aerial vehicles (UAV) are to accompany helicopter operational units and assume or support parts of missions such as reconnaissance, exploration and identification. The control of unmanned aerial vehicles is not envisaged to occur from a ground station, but from the flying units.

The data collected by the unmanned aerial vehicles will also be communicated directly and in real-time to the operational unit.

Against this backdrop the Federal Office of Defence Technology and Procurement (BWB) commissioned a four-year study to explore and/or development of this capability: "Manned Unmanned Teaming (MUM-T)". The contractors were the firm ESG (operational issues, use of MUM-T, networked realistic scenario simulations, flight experiments with manned components), the Universität der Bundeswehr München, (human-machine interfaces, UAV on-board intelligence, assistance systems for UAV operators) and the DLR Institute of Flight Systems.

The focus of the DLR commission was to create a general safety concept for flying manned and unmanned aerial vehicles in joint mission airspace. To this end, procedures for implementing critical parts of missions were compiled, technical safety systems for manned and unmanned components developed and tests for these processes and systems conducted on a simulation basis and in real teaming flight experiments.

As part of the EU VITAL project, the partners SNECMA (France), CIAM (Russia), COMOTi (Romania) and DLR have agreed on the goal of developing highly efficient, low-noise and low-cost contra-rotating fans. Concepts and possible solutions were developed and explored over six years of research work in order to fulfil these conflicting goals and further multidisciplinary requirements with the best compromises available. For the first time, AutoOpti, a multidisciplinary design system developed by the Institute of Propulsion Technology, was implemented for the CRTF2b contra-rotating fan type designed by DLR. The type put forward by DLR concentrated on a maximum level of efficiency, low blade count ratios and light weight, and was measured on the CIAM acoustic test bench in Moscow in Winter 2010/2011.

In addition to classical characteristics, the measurements included an acoustic evaluation and hot-wire measurements carried out by DLR. After just the first evaluation it was established that the design goals had been achieved in their entirety. The level of efficiency exceeds other types for all relevant speed ranges.



Pre-assembled and instrumented rotors of the CRTF2b contra-rotating fan

## Contra-Rotating Fans

### DLR design with optimum efficiency

The architecture of future engines will be decisively determined by the thrust-producing component, the fan. Projects funded by the EU, such as VITAL and DREAM, show the strong need for research to precisely determine the potential of various fan configurations and to provide a basis for future production developments - both for the entire aircraft and the engine.





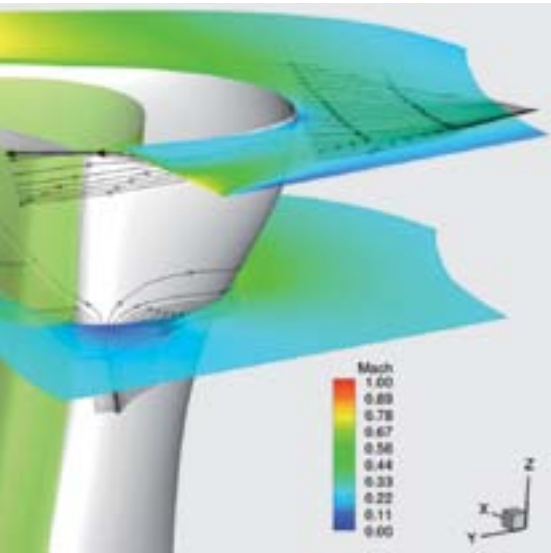

Mach number level in the blade tip area of a turbine rotor

## OmniTURB

### Design and optimisation of turbine geometry

As part of DLR OmniTURB project the Institute of Propulsion Technology demonstrates its abilities in computer-assisted numerical design and optimisation of turbine geometry in the Turbine Department (Göttingen). In parallel with its industrial project partner Rolls-Royce Deutschland, DLR conducted aero-thermodynamic optimisation of a modern, cooled, two-stage high pressure turbine for potential use in future aircraft engines.

The calculation of flow around the complete three-dimensional parameterised geometries of blades and endwalls was conducted, the results analysed and the shape adjusted within selected limits using the institute's own modern tools, such as the AutoOpti optimisation code and the TRACE CFD programme. In comparison to the start configuration, a significant increase in efficiency of 2.1 per cent was achieved by the automated application of complex geometric details, such as non-axis-symmetrical endwall contouring and local blade deformation. This value is high for a component whose efficiency is generally already approximately 90 per cent. Such an increase in efficiency will lead directly to reduced fuel consumption in future realistic engines and thus to reduced emission of pollutants.

## Volcanic Ash in Engines

### High temperature corrosion of ceramic thermal insulation on turbine blades

Against the backdrop of the recent volcano eruptions in Iceland, Chile and Indonesia, possible damage to aircraft engines from drawn in volcanic ash is increasingly becoming the subject of research, both on an academic and industrial level. This damage is of particular relevance to the field of high pressure turbines, where the first-stage stator and rotor blades, which are subject to the highest levels of thermal stress, are directly exposed to the flow of completely or partially melted volcanic ash particles. These turbine components are protected from thermal overloading by both cooling holes and ceramic thermal insulation. Volcanic ash that is drawn in and deposited on the turbine blades lead to immediate safety-related effects, such as blocked cooling holes. However, long-term effects impacting on life span, such as flaking of the ceramic thermal insulation, are also potential results.

At the Institute of Materials Research failure mechanisms made from zirconium oxide thermal insulation, which is state-of-the-art technology in aircraft engines, and new coating materials are explored for future engine generations.

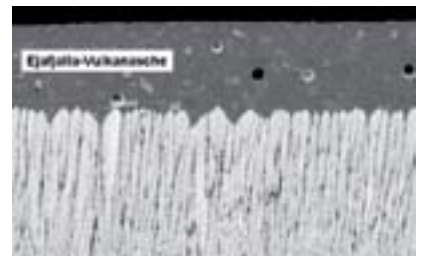

Zirconium oxide thermal insulation with a coating of partially melted volcanic ash from the Eyjafjallajökull volcano



The results show that new coating materials, such as gadolinium zirconate, demonstrate a considerably higher level of stability to volcanic ash under typical current operating conditions. However, in the view of expected higher turbine inlet temperatures in the future, improvements in protective coatings and damage analysis must be systematically expanded. DLR research will thus also contribute to being better able to assess the effects of volcano eruptions on engines in future events.

## IGOS

### Passenger aircraft as measuring devices for atmospheric observation

Documentation of the constantly changing atmosphere demands continuous observation. There is, however, a lack of an infrastructure alongside satellites and ground-supported measurements for continuous measurements in the tropopause region (9–13 km), although it is precisely here that the effects of the changing climate are revealed.

The European infrastructure IAGOS uses passenger aircraft to carry measuring devices for trace gases and particles relevant to climate. The project is coordinated by the Forschungszentrum Jülich and comprises 16 partners, including Airbus, Lufthansa and British Airways. Up to 20 commercial aircraft conduct continuous measurements with permanently installed sensors. In addition, every three weeks a special measuring container with a payload of 1.5 tonnes is used on a Lufthansa A340. Under the responsibility of DLR, the instrument will be developed and implemented to measure airborne particles (aerosols), as well as nitrogen. Just as before, the role of

aerosols and nitrogen in the climate system is not completely understood, so DLR is contributing important components to IAGOS. The data gathered will make a considerable contribution to the quantification of the influence of air traffic on the atmosphere and climate.

In close cooperation with manufacturers and aircraft technology companies, measuring devices were modified for use in passenger aircraft. An inlet system was also developed for sampling and simulated for cruising altitude conditions. Airbus made the flow field of an A340-300 available for this purpose. The entire package is currently being prepared and comprises measuring instruments and admission for the allowance for operation on passenger aircraft. As well as its deployment as part of IAGOS, the aerosol measuring package developed here will serve as a basis for a future volcanic ash warning sensor.



IAGOS inlet system

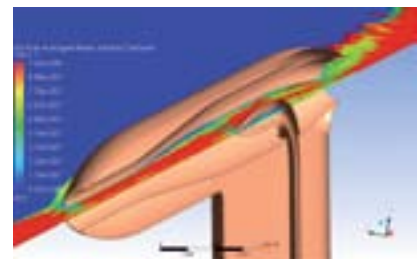

Simulation of the trajectories of individual aerosol particles to determine the collection characteristics of inlet systems at cruising altitude



Physical tests on oxygen supply in DLR's baromedicinal laboratory

## SAPOX

### Investigations into new designs for aircraft oxygen systems

Oxygen masks for passengers are a good 50 years old in their technological concept. With the development of new wide body aircraft focussing on weight-saving and fuel economy, emergency oxygen supply has also come into consideration as a permanent constituent of the empty weight. A weight saving of approximately 20–30 per cent is hoped for by implementing new technologies.

Currently, the design provisions defined in international regulations are only tailored to the traditional construction of the familiar yellow "coffee cups". Allowing new systems demands that the corresponding conditions are revised and formulated in a way that is as technology-neutral as possible. In this regard Ordinance CS 25.1443 c) on altitude-dependent oxygen dosage for passengers at a constant flow is in focus. A corresponding EASA contract, SAPOX (Safety of Pulsed Oxygen Systems) was given to a Franco-German consortium that included the DLR Institute of Aerospace Medicine.

New criteria that ensure sufficient oxygen supply to passengers in the event of a loss of cabin pressure were tested in experiments at the DLR institute's baromedicinal laboratory at the end of 2010. This proved pulse oximetry to be helpful. Here, arterial oxygen saturation of the blood is calculated non-invasively as a considerable physiological parameter via an optical method. In order to illustrate the actual risk in the aircraft cabin in times of demographic change, the investigations were conducted mainly on older people at altitudes of up to 40,000 feet. With a blood oxygen saturation of at least 90 per cent of the people in the group over 50, the protection goal was

achieved. The present concluding report recommends a corresponding revision of CS 25.1443 c) and further investigations for regulations relevant to the crew are being discussed.

## UNITAS IV

### Robust Galileo/GPS navigation multi-antennae for aeronautics

Reliable satellite navigation is an essential precondition for current and future aeronautics. However, it has recently become clear that there are increasing restrictions in the availability of this technology. The reason is accidental or deliberate interfering signals, which negatively affect or entirely block navigation reception. A typical example of these types of interfering signals is personal privacy devices, which lead to massive availability problems for the FAA GBAS station at Newark Airport. Although these types of devices are illegal, they are still used by a large number of lorry drivers in the USA in order to interfere with the lorry's GPS reception and thus avoid their employers' fleet monitoring.

The Institute of Communications and Navigation developed the first GPS/Galileo receiver demonstrator with an adaptive antennae array that can suppress the interfering signals and thus allow particularly robust navigation. Although the potential of "adaptive antennae" technology is recognised in the professional world, practical realisation or even validation has not yet been achieved. The GPS/Galileo receiver demonstrator developed by the Institute of Communications and Navigation was thus tested in flight experiments during the UNITAS IV project. The flight experiments were conducted together with the Technische Universität Braunschweig. The results show reliable functioning of the algorithms for beamforming and directional estimation under typical aeronautic conditions and a considerable improvement in efficiency compared to traditional navigation receivers.

# Outlook

The numerical simulation represents a key technology for the design of future aircraft. Continuing increases in computational power suggests implementing simulations in a considerably more far-reaching manner and completely remodelling the development process for aircraft. The vision of "Maiden Flights on the Computer" resulting from this is a central element of the Helmholtz Association (HGF) application portfolio "High-Performance-Computing-4-Digital-X", which was approved in June 2011: conception, design, construction and communication of the flight characteristics of an aircraft are to be based solely on numerical simulation.

The associated requirements comprise developing a flexible canonical flow solver, the simulation of a manoeuvring elastic aircraft, capacity for multidisciplinary optimisation and adjustment to future high-performance computer systems. Together with its associated partners Airbus and Forschungszentrum Jülich, DLR will use its scientific and technical expertise in exploring, developing, coupling and applying cross-disciplinary simulation systems in order to embrace the requirements and gradually approach the vision.

**Aeronautics: Revenues in millions of euros**

	<b>2010 actual</b>	<b>2011 planned</b>	<b>2012 planned</b>
Basic funding	129	135	135
Third-party financing	76	73	74
<b>Total revenues</b>	<b>205</b>	<b>208</b>	<b>209</b>

**Expected revenue for the year 2011**

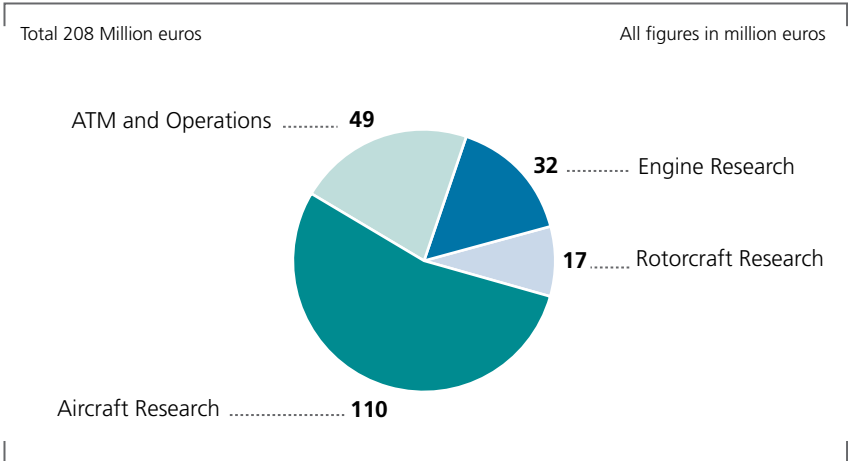



# Space

## Space Administration, Space Research and Technology

Germany's national and international space exploration activities come together at the German Aerospace Center: Research work is carried out by the DLR Space Research institutes, whereas policy issues are the remit of the DLR as Space Agency, which is responsible for pursuing national and international space-related activities on behalf of the Federal Government of Germany. DLR's own research institutes have the task of contributing to the scientific, technological and operational activities. The integrated

German space programme combines German participation in the European Space Agency (ESA) programmes, the EUMETSAT organisation, the National Space Programme, the DLR "Space" R&T programme and additional space-related activities in science and industry. Through these activities, DLR is in a prominent position to demonstrate its expertise and capabilities in collaborations with partners on national and international space flight missions and research projects. The following examples provide a brief overview of successes and events during the past year. Due to DLR's double function as Space Agency and research institution, there are three different types of results:

- Space Administration highlights,
- joint projects in Space Administration and DLR's own Space Research and Technology,
- Projects in DLR's Space Research and Technology.

## Space Administration highlights

### New German Space Strategy

In its cabinet meeting on 30.11.2010, the federal government approved the new German space strategy. The German Minister of Economics Rainer Brüderle presented it to the space community at a large opening event in Berlin on 01.12.2010.

This paper fundamentally establishes how space flight is to develop on a national level over the coming years, and also in reaction to the changing international political and social conditions. The strategy was introduced by BMWi. It was developed in conjunction with other ministries active in space flight and in agreement with scientific and economic institutions such as DLR.

The new space strategy replaces the federal government's last space programme, which was approved in 2001. The new strategy represents the position that in recent years space flight has developed from a scientifically characterised symbol of technological competition to an instrument for overcoming social problems and global challenges, such as climate change and security and defence measures.

### 221st ESA Council

On 16 and 17.03.2011 the ESA Council convened for its 221st meeting. During the meeting, the council implemented Director General Jean-Jacques Dordain's extensive restructuring measures. In accordance with these changes, a team of directors was appointed that began its work on 01.04.2011. All directors have been appointed for a four-year period of office.

An overview of the directorate and its members:

- New Directorate of Human Spaceflight and Operations (D/HSO): The council has appointed Thomas Reiter (DE) as director.
- Directorate for Procurement, Finance Operations and Legal Affairs: Eric Morel de Westgaver (BE)
- Directorate for Human Resources, Facility Management and Informatics (D/HFI): Hans-Georg Mockel (DE) (currently Chancellor at the Goethe University Frankfurt)
- Directorate for ESA Policies, Planning and Control: Giuseppe Morsillo (IT)
- Directorate of Science and Robotic Exploration (D/SRE): Alvaro Giménez Cañete (ES)
- Directorate for the Galileo Programme and Navigation-related Activities (D/NAV): Didier Faivre (FR)
- Directorate of Technical and Quality Management (D/TEC): Franco Ongaro (IT)
- Director of Corporate Reforms (D/CR; Coordination of Financial Management Reform, Financial Regulations, Administrative and Finance Committee, ESA's Efficiency Project and Sites and Infrastructure Policy): Gaele Winters (NL)

At the same council meeting the continuation of the European ISS operation programme was also decided upon. Those involved in the programme agreed on a capped financial framework (CaC) of 2.6 billion euros (WB 2011).

The intention is that further binding financial commitments will be concluded and approved as part of the overall financial framework at consecutive minister conferences.

At the council meeting in March, the participating states secured assistance measures for Arianespace for carrier occupancy on the basis of due diligence on Arianespace's financial status (Slice 13 Ariane-5 development programme). The condition for this is greater transparency for the participating states. It is expected that the council will make a final decision on European carrier occupancy in October 2011.



**Space Administration: Revenues and funding budget in millions of euros**

	<b>2010 actual</b>	<b>2011 planned</b>	<b>2012 planned</b>
Third-party funding (Management for Federal Ministries)	23	27	28
National programme (incl. proportionate management for BMWi contract)	225	242	270
ESA (total incl. BMVBS et al.)	654	713	743
<b>Total</b>	<b>902</b>	<b>982</b>	<b>1042</b>



The Alpha Magnetic Spectrometer magnet in the integration hall at CERN

## AMS

### Endeavour transports camera for dark matter to ISS

On 16.05.2011 the space shuttle Endeavour (STS-134) took off on its flight to the ISS. On board was the Alpha Magnetic Spectrometer (AMS), a detector for particles of cosmic radiation from space. The results are expected to provide clues to the existence of what is known as dark matter.

To date its existence has not been proved. In order to trace dark matter the AMS spectrometer identifies a wide range of particle types by determining their load and mass and measures their energy spectrum. The centerpiece of the 4 m<sup>2</sup>, 7 tonne apparatus is a strong magnet in the middle. The particles deflected by the magnetic field describe a curved field that is measured with silicium trackers. A laser alignment system developed and built by the RWTH Aachen monitors the stability of these trackers with a precision of 5 micrometres.



ATV-2 in flight

Surrounding the magnet is another RWTH development: the so-called veto counter, which measures deviations and prevents particles approaching from the side from distorting the results. Germany is involved with the Transition Radiation Detector (TRD), which can differentiate between various types of elementary particles. The data delivered by the TRD is registered by a recording system that was developed and built at the Universität Karlsruhe.

Approximately 500 scientists from 16 countries have participated in the 1.5 billion-euro AMS project – German scientists and top German technology have significant involvement. DLR Space Administration offers support in this regard with funding from the National Space Programme.

## “Johannes Kepler”

### Successful ATV mission

On 21.06.2011 the European “Johannes Kepler” ATV-2 space transporter entered the Earth’s atmosphere and burned up over the South Pacific. After a good four months in space, the ATV-2 had undocked from the ISS on 20.06.2011. On board was a re-entry break-up recorder, which recorded all mechanical stresses during the break up of the ATV and transmitted the data via satellite to ground control.

The ATV-2 initially re-boosted the orbit of the ISS by more than 30 kilometres. After launching with an Ariane-5ES on 16.02.2011 the “Johannes Kepler” ATV-2 docked completely automatically at the ISS on 24.02.2011 and delivered a total of 7.1 tonnes of cargo. In addition to the re-boost, it also provided position control on several occasions after the docking and undocking of Sojus and Progress spacecraft and the space shuttle.

Joint Projects in Space Administration and DLR's own Space Research and Technology

## The SOFIA Flying Observatory

**First scientific flight with the German instrument GREAT**

German scientists conducted astronomic observations on board SOFIA (Stratosphere Observatory for Infrared Astronomy) for the first time on 06.04.2011. SOFIA, the only flying observatory in the world, is a joint venture between DLR and NASA. It is realised with funds from the National Space Programme, the federal state of Baden-Württemberg and the University of Stuttgart.

The German instrument GREAT (German Receiver for Astronomy at Terahertz Frequencies) was put to scientific use for the first time. With its spectroscopic observations were conducted in the direction of M17, a region with intensified star formation in our Milky Way and Galaxy IC342, which is only a few million light years away.

GREAT is a spectrometer for observations in the far infrared area of the electromagnetic spectrum for frequencies between 1.2 and 5 terahertz (60 to 220 micrometre wavelength), which cannot be accessed from the Earth's surface due to water vapour absorption in the atmosphere. GREAT was developed by the Max Planck Institute for Radio Astronomy and the University of Cologne in cooperation with the Max Planck Institute for Solar System Research and the DLR Institute for Planetary Research.

## International Charter Space and Major Disasters

On 19.10.2010, DLR joined the International Charter Space and Major Disasters at an event in Paris celebrating its tenth anniversary. As the eleventh Space Agency DLR thus agrees to contribute its competencies and resources, particularly in the area of Earth observation, to handle natural catastrophes and major disasters.

DLR has already played an active role in the Charter in the past. TerraSAR-X data has repeatedly been requested and duly provided to numerous Charter projects since its launch in June 2007.

The Charter is an international treaty between space agencies and satellite operators. The signatories to the Charter are committed to supporting crisis management work in response to disasters by making their space-based infrastructure available to the parties involved. Since it was founded, the Charter has been invoked 280 times, meaning that it has been possible to quickly supply maps derived from satellite imagery. Examples include the flooding of the River Elbe in 2002, the tsunami in the Indian Ocean in 2004, the earthquake in Haiti in 2010 and the tsunami catastrophe in Japan in 2011, which is mentioned in the Security and Defence section.



## Ten Years of ISS Usage

### Scientists happy with the interim state-of-play

Ten years ago the very first physical and radiobiological experiments were conducted on the ISS – with substantial German involvement. To celebrate this anniversary, DLR Space Administration organised a scientific symposium in Bonn on 23. and 24.03.2011. Leading space scientists from German universities and other research institutions presented the results of completed and ongoing ISS experiments. Furthermore, they gave an outlook on future projects at the space station.

A total of 56 scientific and technological experiments from Germany have been or are being conducted at the ISS, of which 38 have been completed.

## GATE

### Galileo test region opened in Berchtesgaden

On 04.02.2011, the Federal Minister of Transport Dr. Peter Ramsauer opened GATE, Germany's most technologically comprehensive Galileo test environment, in Berchtesgaden.

Europe's future satellite navigation system will come into operation in 2014. The GATE test environment ensures that science and industry can conduct advance tests for their applications under real operating and environmental conditions. In the GATE test region in Berchtesgaden, eight transmitter stations installed on mountain peaks transmit so-called pseudolite signals, which conform to those of the Galileo satellites to be stationed in the Earth's orbit from 2014.

The development and the construction of the test environment was financed by DLR with funding from the Federal Ministry of Economics and Technology (BMWi) and by a consortium (comprising DLR and Fraunhofer research institutes, industrial enterprises and the Universität der Bundeswehr München).

## Rosetta

### Rosetta spacecraft returns unique glimpses of asteroid Lutetia

The European Rosetta spacecraft has achieved a further milestone on its journey to the comet Churyumov-Gerasimenko. In July 2010, the orbiter flew past asteroid Lutetia at a distance of just 3,162 kilometres. Lutetia is the largest asteroid that a space mission has ever visited, and DLR is significantly involved in this pioneering mission. This is how, for example, the OSIRIS camera, which was developed in cooperation with European partners, was funded by DLR Space Administration under the leadership of the Max Planck Institute for Solar System Research in Katlenburg-Lindau. DLR's scientific involvement in Rosetta is coordinated by the Institute for Planetary Research.

This fly-by offered the unique opportunity to examine the size, surface structure and rotational characteristics of this relatively large asteroid that had never been explored from close range. The data gained will provide clues to the age, mineralogical and geochemical composition and geological history of Lutetia. Examinations of the small bodies of the Solar System – of which asteroids Lutetia and Steins are two – has delivered important information regarding the earliest periods of the Solar System. The fly-by was a choice opportunity to test all the orbiter's instruments and several of the lander's experiments, because in July 2011 the Rosetta probe was put into a 2.5 year hibernation. It will awake again in January 2014 and prepare for the arrival of Churyumov-Gerasimenko.

## Mars500

### Research under Controlled Conditions



With the simulated Mars landing in February 2011 the Mars 500 project for the six "cosmonauts" in an isolation container at the Moscow Institute of Biomedical Problems (IBMP) reached a new phase. After 256 days of the study to date, the German scientists involved began to assess their experiments. A total of eleven German experiments were conducted within the Mars500 study as part of the National Space Programme, of which five involved the DLR Institute of Aerospace Medicine. Investigations included, for example, the effects of reduced salt intake on metabolism, the regulation of the blood pressure of the test subjects and how bone metabolism changes during the isolation period. The strict nutrition and limited activities of the test subjects on the



Mars spacecraft offered the scientists a good basis for this. Other DLR scientists at the Institute of Aerospace Medicine were involved in experiments that also have great importance for space flight. While biologists are investigating the development of microbial flora in the closed area of the spacecraft and its crew, psychologists are exploring computer-based training of complex control tasks and the group dynamic of the Mars500 crew.

## REXUS 9 and 10

### Research rockets take student experiments to the edge of the atmosphere

In February 2011, the REXUS 9 and 10 research rockets successfully launched from the Esrange Space Center in the northern Swedish town of Kiruna. On their approximately five-minute flights, the rockets of DLR and the Swedish Space Agency SNSB almost reached the boundary of space at an height of approximately 80 kilometres. On the REXUS 9 and 10 rockets, student groups from Germany, Ireland, Italy, Austria and Sweden tested technologies for space and atmosphere research and investigated the behaviour of metal particles and liquids under zero gravity conditions. The German-Swedish REXUS/BEXUS programme (Rocket/Balloon Experiments for University Students) allow students to gain their own practical experience of preparing and conducting space projects. The German REXUS projects are led by the Institute of Space Systems in Bremen. The flight campaigns are conducted by EuroLaunch, a joint venture between DLR's mobile rocket base (MoRaBa) and the Swedish Space Agency, the Swedish Space Corporation's (SSC) Esrange Space Center. DLR Space Administration in Bonn led the programme and managed the call for proposals.

## TanDEM-X

### First 3D pictures shortly after launch

On 22.07.2010, only a month after the start of TanDEM-X, scientists from DLR in Oberpfaffenhofen successfully published the first 3D pictures from the satellite mission. In order for 3D pictures and altitude models to be recorded, TanDEM-X and, since 2007, its twin satellite in space TerraSAR-X, must fly in close formation and simultaneously record the same areas of the Earth from different perspectives. The flexible formation flight of the two radar satellites allows the data gathered to be analysed for a wide range of investigations of the Earth.

As well as the volcanic region of the Atacama Desert, this TanDEM-X photograph shows the Salar de Uyuni, which at a total of 10,000 m<sup>2</sup> is the largest salt basin in the world. The blue and dark blue colours mark the salt plain as the deepest area. The educated eye can also read the rock strata boundaries from the altitude model. This knowledge of the Earth's surface allows important conclusions to be drawn regarding the formation and composition of the terrain.

During an overflight of the Italian volcano Etna, the satellite pair of TanDEM-X and TerraSAR-X simultaneously photographed an object on the Earth's surface in exactly the same microsecond for the first time. Using the data gathered, DLR scientists created a three-dimensional altitude model with a previously unachieved altitude accuracy of up to two metres.

The TanDEM-X mission is conducted by DLR with funding from and commissioned by the Federal Ministry of Economics and Technology (BMW) within the framework of a public private partnership (PPP) with Astrium GmbH.



Student teams from REXUS 9 and 10



TanDEM-X photo: Salar de Uyuni, the largest salt basin in the world and the volcanic region of the Atacama Desert





Assembly of the SHEFEX-II tip

## Projects in DLR's Space Research and Technology

### "Tips"

#### Technology from Germany

With SHEFEX II DLR is taking a new path in the development of a future spacecraft: Sharp corners and edges are intended to make re-entry into the Earth's atmosphere cheaper, safer and more flexible. After three years in development, the angular payload has been revealed to the public at DLR Stuttgart. The two-metre-long spacecraft is currently being subjected to comprehensive testing at DLR Oberpfaffenhofen and being mounted the tip of a two-stage sounding rocket. This is to be launched from the Andøya Rocket Range (ARR) testing area in northern Norway in 2011. SHEFEX II is testing nine different thermal shield systems, which are largely designs from DLR's so-called fibre ceramics. In addition and in contrast to its predecessors, SHEFEX II has small stub wings, so-called canards, with which the craft can be controlled. Behind the SHEFEX programme is the idea of testing new re-entry technologies for space flight as cost-effectively as possible in flight experiments. The aim of the development is a unique space glider called the REX Free Flyer, which is to be made available for traceable experiments under zero gravity conditions from 2020 on.

## Air and LIDAR

### Laboratory tests and measurements at Germany's highest environmental station

At the Schneefernerhaus Environmental Research Station, a scientist from the DLR Institute of Atmospheric Physics has improved a special model to interpret LIDAR (Light Detection and Ranging) data. To date, this so-called Tenti model has only been investigated for its validity in molecular gases, but not in gaseous mixtures such as air. The basic research that was lacking here has now been provided in cooperation with the Free University Amsterdam in preparation for the ESA meteorological Atmospheric Dynamics Mission (ADM-Aeolus). ADM-Aeolus is based on LIDAR measurements, during which short, high-energy laser impulses are sent through the atmosphere where they meet air molecules, dust and ice particles. The light that is scattered in the process is analysed. Conclusions regarding the prevailing wind speeds in the atmosphere can be drawn from its properties. Improvements increased the correspondence of measurement and model to 98 per cent. The measurements thus offer the assurance that negligible errors occur during the analysis of LIDAR data using the Tenti model. ADM-Aeolus is expected to launch in 2012 and improve the computer-assisted weather forecast and the understanding of dynamic processes in the atmosphere.

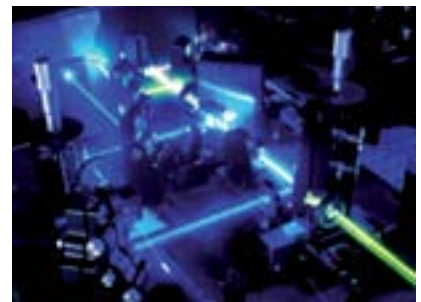

Physical tests on scattering of light



## Mapheus-2

### Experimenting under zero gravity conditions

In October 2010 DLR Mapheus-2 (Material Physical Experiments under Zero Gravity Conditions) research rocket launched from DLR Space Operations' MORABA (Mobile Rocket Base) in the northern Swedish town of Kiruna. On board were three material physics experiments by the DLR Institute for Material Physics that were subjected to zero gravity conditions for three minutes and thoroughly analysed by DLR scientists after the flight. The experiments for this flight were developed and built in order to investigate three very fundamental processes. In the "ATLAS-M" (Atomic Transport in Liquid Alloys and Semiconductors in Mapheus) experiment the scientists wished to investigate diffusion in molten metals. The results serve both to describe processes of diffusion and solidification and to further develop new experimental methods that can be applied in ground-level laboratories. In the DEMIX-M experiment the scientists are investigating so-called separation of liquid metals. The results could contribute considerably towards developing physical model representations of separation – a basis for casting simulations of workpieces. The third experiment deals with magnetically excited granular material. In the MeGraMa-M (Magnetically Excited Granular Matter on Mapheus) module, kinetic energy can be introduced to a granular system under zero gravity conditions in a targeted manner. In addition, paramagnetic particles are used, which are excited via variable magnetic fields. It is therefore also possible to introduce energy to the system's interior, and the energy can be homogeneously distributed. As soon as this happens, the magnetic fields are turned off and DLR scientists can observe the granular cooling under undisturbed conditions.

## Mars-Rover

### Obstacle course provides Mars-like test conditions

Researchers at DLR Robotics and Mechatronics Center (RMC) have built a challenging obstacle course, which really puts the ExoMars rover to the test. ESA, which wishes to send the rover into space, has set rigorous specifications for the tests it has to pass. It must climb over stones and up Mars dunes. It must be able to drive up slopes of 26 degrees to meet ESA's specifications. Infrared cameras follow the rover's every movement and at the end of the test sequence, another camera system scans the entire surface of the test tank so that the computer can build a three-dimensional map of the surface. The vehicle's tracks and all the obstacles are precisely recorded. The computer simulations are optimised using the data gathered. Later, many tests for the ExoMars rover will not have to be conducted in the 'real' world, because computer simulations will give the researchers the information they require. The findings could also be useful for future missions: if the plan is to allow a rover to travel independently over unfamiliar terrain using a stereo camera to guide it, or to use a swarm of small crawlers – crab-like rovers with many legs – these activities can be tested out in computer simulations before the event.



Challenging Martian surface



EXPOSE-R with microorganisms outside the ISS

## MiroSurge

### A new stage of development for surgery

In 2010 the Medical Robotics project group at DLR Robotics and Mechatronics Center (RMC) presented a new stage in the development of MiroSurge robotics systems for minimally invasive surgery at the AUTOMATICA trade fair for the international surgery and medicine technology industry. The very positive reactions intensified the goal of this development: providing the surgeons the most ergonomic and variable way of working. The Helmholtz Association (HGF) was successfully engaged to fund developing closer cooperation with clinicians. As part of this MIRO laboratory project, commercialisation of the system was prepared and a medical robotics laboratory constructed, in which long-term applied research with clinics and industry could be conducted at DLR Oberpfaffenhofen.



DLR MiroSurge robotics system

## Survival Experts

### Microorganisms in space

Spores of bacillus subtilis have spent 22 months in the 'EXPOSE-R' test container outside the ISS. For the first time during a long-duration mission, they were mixed with artificial meteorite dust and exposed to the harsh conditions of outer space. Since this experiment began back in March 2009, almost 300 microorganism samples have been subjected to harsh conditions. Using optical filters and various artificial meteorite materials, we have created different UV radiation conditions for these microorganisms. Some of the samples were exposed to an inert gas atmosphere, while others were exposed to vacuum conditions. In addition, the samples were subjected to ionised radiation, zero gravity conditions and temperature fluctuations. At intervals with the ISS experiment, researchers at the DLR Institute of Aerospace Medicine conducted the experiment on the ground in their Planetary and Space Simulation Facility in order to obtain a comparative sample set. Scientists at DLR are now determining how many of these spores have survived the mission. If it turns out that the meteorite dust was able to shield the spores from the hostile space environment, microorganisms may be capable of surviving in meteorites for long periods of time and travelling from one planet to another.

## Ozone Layer

### Climate chemistry models in long-term simulations

Researchers at the DLR Institute of Atmospheric Physics have been instrumental in the preparation of a report on the development of the ozone layer in the stratosphere for the World Meteorological Organization. Recent estimates suggest that, by the middle of the 21st century,

the thickness of ozone layer will be at least the same as in the early 1980s and that the ozone hole over the Antarctic will have closed as much as possible if the Montreal Protocol commitments continue to be followed strictly. The basis for the forecasts in this report is known as climate chemistry models, which have been produced at institutions including the above-named DLR institute. Long-term simulations to investigate the ozone layer are conducted there, during which the computational results for the past are compared with observation data. Delivering reliable estimates relating to future developments is only possible on the basis of thoroughly tested models. To gain an understanding of atmospheric processes, atmosphere researchers use data from the DLR Remote Sensing Technology Institute. This satellite data will, for example, be compared with other independent data so that the process will culminate in high-value, quality-tested data that scientists can work with.

## Outlook

For DLR, space research involves research and development that directly benefits people while at the same time being our inspiration for the future. The challenges for the long-term preservation of the basis on which we thrive, which face humankind as a part of a changing world, can only be approached scientifically if correspondingly suitable data and information about the Earth and what is happening on it are available. Space flight plays a crucial role in this respect. Space flight also means pushing research to completely new dimensions. Space flight profoundly affects our vision of the actual Earth and the world beyond our planet. How did the cosmos come into being? Does life exist outside Earth? How does the space environment affect processes in the life sciences and materials science? These are all questions that affect people. Space flight offers unique new ways of answering these questions.

Space R&T Revenues in millions of euros

	2010 actual	2011 planned	2012 planned
Basic funding	154	157	166
Third-party financing	154	146	138
<b>Total revenues</b>	<b>308</b>	<b>303</b>	<b>304</b>

Expected revenue for the year 2011

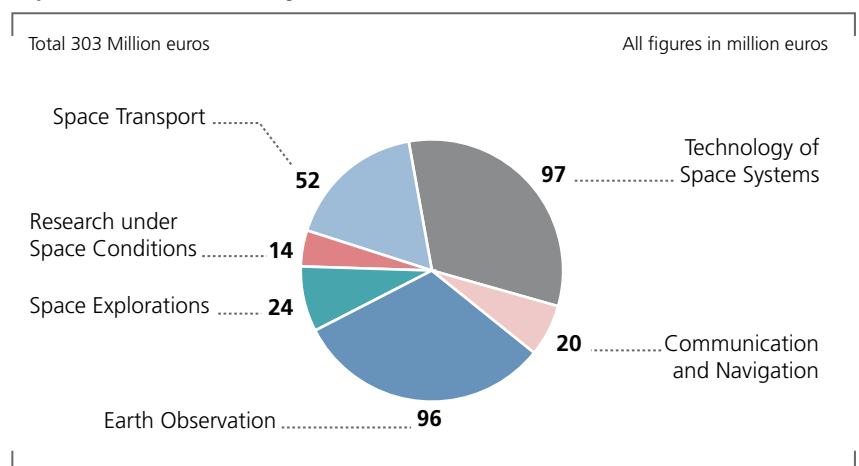

In the Helmholtz space programme, potential space applications are developed, work is carried out on technical solutions and specific scientific and application-related missions are prepared. All this happens in conjunction with partners from industry, research bodies, universities and government agencies and authorities, acting as a central link between all the key players involved in space flight and taking projects from an idea to execution to application in space flight.



# Transport

The transport sector is essential for modern society. It satisfies individual needs for mobility, generates employment, and represents a substantial proportion of added value in the economy. This is especially true for Germany with its export-strong economy and central transit position at the center of Europe. However, transport also has undesirable consequences. Noise and exhaust fumes harm humans and the environment, countless people become victims of accidents. Solving these conflicting aspects is amongst the major challenges of our time. This is precisely where the DLR transport programme's research is applied: How do we shape a modern transport system that is sustainable over the long-term, both economically and in terms of its social and ecological impact? This overarching question accompanies us on the search for concrete answers. On the following pages, we will present a selection from the diverse results of our research work during the period 2010–2011.

## VABENE

### Transport management in extreme situations

Major events, large-scale emergencies and catastrophes endanger the functionality of the transport system. On the other hand, it is precisely the transport system that takes on a significant role after these occurrences; emergency services use the transport infrastructure in order to ensure transport and deployment logistics. It is also important to maintain the mobility of the population as much as possible. The VABENE project is aimed at offering the emergency services efficient support vehicles for decision-making. VABENE's central element is the so-called crisis simulator. This processes the initial situation, infrastructure and transport information to give a comprehensive illustration of the current overall traffic situation. This also forms the basis for forecasting future transport developments using simulations. In addition, automatic action recommendations can also be derived by taking into account further boundary conditions. This information is made available to emergency services on site and in the respective coordination centers so that decisions can be better coordinated and effects more soundly analysed. Sensors linked to ground and infrastructure often have only limited availability in the event of a crisis. Our airborne traffic and situation capture systems thus provide important supplementary data in near real-time. The intelligent coupling of this different sensor information and comparative assessment with historical inventory data are further keys to VABENE's success.



In a large-scale test on the occasion of the Munich Oktoberfest 2010, DLR scientists supported employees at Munich's traffic control center. Traffic data from approximately 4,000 taxis in the Floating Car Data Fleet and transport information from stationary measuring stations in the Greater Munich area was conflated to give the current overall traffic situation and forecasts regarding traffic developments in the following 30 minutes derived from this. After its successful implementation at the Oktoberfest, the first test of the entire VABENE system took place in June 2011. As part of this and in contrast to the Oktoberfest, airborne transport situation capture was also used. The internal project objective of making aerial photographs and traffic information gathered from these available in near real-time was successfully implemented. In addition, the mobile ground control that had been implemented for the first time and which functioned as a local situation center, demonstrated its efficiency.

## Shipping

### Impact on the atmosphere and climate

In 2000 approximately 800 million tonnes of carbon dioxide (CO<sub>2</sub>) were expelled by ship engines on the world's oceans. This figure is almost equal to that of air traffic. However, with more than 20 million tonnes of nitrogen oxides (NO<sub>x</sub>), shipping exceeds air traffic by ten times, and with approximately 12 million tonnes of sulphur dioxide (SO<sub>2</sub>), it exceeds it by as much as 100 times. This fact is primarily due to the fuels used, which have a high sulphur content. Since 2004, ten young scientists and Ph.D. students from DLR and the University of Bremen have concerned themselves with the effects of shipping emissions on the atmosphere and the climate as part of the Helmholtz University Young Investigators Group SeaKLIM.

In their concluding report, which they presented at the end of 2010, they came to notable results. Shipping contributes to global warming through carbon dioxide emissions. Nitrogen oxide emissions also increase the effect of global warming through ground-level ozone creation. Furthermore, ozone is detrimental to human health. The high concentration of SO<sub>2</sub> emissions appears at first glance to counter global warming, as sulphur dioxide and other sulphurous compounds initially react to form sulphuric acids in the atmosphere. Together with water, these then form aerosols. These aerosols change the characteristics of clouds so that they reflect more solar radiation into space and less heat radiation is present on the Earth's surface. However, this only happens only for a short time and is limited locally, while carbon dioxide remains in the atmosphere for over 100 years.

The concrete findings of the SeaKLIM group and its supplementary evidence of massive air pollution in coastal regions have contributed to the introduction of drastically stricter rules for minimising SO<sub>2</sub> emissions for international shipping. They have also been used in the International Maritime Organisation's Second Greenhouse Gas Study.



Mobile VABENE ground control in field test



Container ship with exhaust plume





Sleeping for science

## Why We Wake Up

### The impact of traffic noise on sleep patterns

Traffic noise is annoying! Especially at night! These are the unsurprising findings of numerous population surveys. To combat the effects of the noise, we first need to understand how humans react to it. 72 men and women of different ages were thus taken to sleep for eleven nights at a sleep laboratory as part of a DLR study. They were subjected to different loud noises from cars, trains and aircraft in a precisely defined pattern. The team's studies included the influence of noise on the waking response time, brain signals and heart rate. During the morning after their nights in the laboratory, the volunteers underwent various concentration and memory tests. The trial participants themselves also rated the quality of their sleep and the level of disturbance.

A significant finding of the physiological investigations was that at the same volume, noise sources that occur and disappear again quickly, e.g. cars, affect sleep more than those that approach and disappear slowly, e.g. aircraft. However, this was not generally perceived by the test subjects in their subjective assessments. They identified aircraft noise as the greatest disturbance. A possible explanation for this is the duration of the noise. A healthy human wakes up about 20 times a night. In most cases the waking phase is too short for the person to register it or remember, especially in the case of slowly approaching aircraft, which reach their highest volume level overhead and then slowly disappear; the noise is still there after the sleeper has woken up and is consciously registered. It is therefore consciously experienced and the affected person can remember it the next day.

The data assessment taken from the noise-related increase in heart rate showed that there was no getting used to the noise. Even after the volunteers had spent several nights in a row being subjected to the traffic noise, the individual noises still caused their hearts to beat faster. This key result supports the possible link between long-term exposure to noise pollution and the occurrence of heart and circulation problems. Other results from the study show that the frequency of the traffic noise plays a key role in the disruption of sleep. Findings such as these can be used for further research into the optimisation of active and passive noise control methods.

## Road Freight Transport 2030

### Facts, trends and perspectives

Road freight transport will continue to develop dynamically for the foreseeable future. Environmental sustainability, energy balance and impact on the climate will therefore become an increasing focal point. A study on the development of road freight transport in Germany up to 2030 addresses precisely these themes. It was produced by DLR in cooperation with the WeltWirtschaft Institute in Hamburg and commissioned by Shell Deutschland. At the center of the investigation are the heavy goods vehicles (HGVs) used in road freight transport. Based on current transport statistical data, it analyses structures and trends for freight transport vehicles. It also investigates the potential of engine, vehicle and fuel technologies available currently and in the medium term. To this end, future energy consumption and CO<sub>2</sub> emissions for road freight transport and road transport overall are estimated on the basis of the two scenarios. A continuation of current technological

trends is recorded in the trend scenario; the alternative scenario is more ambitiously structured as regards technological development.

A significant result of the study is that road freight transport, but particularly long-distance road freight transport, is becoming increasingly cleaner. However, the elaborate emission treatment technologies that are jointly responsible for this make HGVs more expensive. In recent years they have also led to increased energy consumption. HGVs in 2030 will use greatly improved diesel technology and, depending on driving profile, use hybrid technology and sustainable biofuels as well as combine optimised vehicle technology. Road freight transport's share of total CO<sub>2</sub> emissions, which is currently around 5 per cent, is expected to rise due to HGV transport and driving performance. Due to technological improvements to HGVs, but mainly due to clearly more sustainable passenger vehicle mobility, CO<sub>2</sub> emissions from motorised road transport will remain stable overall in the trend scenario for the period 2005 to 2030. In the alternative scenario, they will fall by 17 per cent.

## Next Generation Train

### More than just a vehicle

With the Next Generation Train project, DLR has been following a holistic approach for future rail vehicles in high-speed traffic since 2007. In the process, the research work extends far beyond simple observation of rail vehicles. Suitable high-speed routes, for example, are thus identified and the interaction between the train and the infrastructure at stations is illuminated.

How could high-speed traffic develop globally in future? DLR's routing tool, which is based on a geographic informa-

tion system, identifies the most cost-effective route between two cities using spatial data. Factors such as terrain gradients, population density and bodies of water determine the course of high-speed routes and influence the construction costs considerably. Based on the altitude profile it is possible to estimate where tunnels and bridges have to be built. In combination with forecasts regarding the development of passenger numbers on the respective relationships, the calculated routes thus allow an assessment of the feasibility of new high-speed routes.

However, it is not only a question of identifying suitable routes for next generation trains. In order to minimise the time double-decker trains spend in stations, the interior design is to be optimised and adjusted to the station infrastructure. Necessary adjustments of the infrastructure and their effects are also to be described. To this end, DLR scientists simulate different vehicle configurations, analyse and assess boarding and alighting times and model the movements of individual persons in the train interior for different arrangements of seats, stairs and doors. On the basis of the rate of passenger transfer in long-distance travel and taking into account technical conditions, the best concept for a smooth flow of passengers and rapid passenger transfer is thus calculated at a simultaneously high level of passenger comfort. To this end scientists work with the TOMICS microscopic fast-time simulation software developed by DLR.



A Next Generation Train emerges from the tunnel



Free-piston linear generator measuring control room at DLR Stuttgart



Free-piston linear generator mounted on the test bench

## Free-Piston Linear Generator

### Range extender – just in case

In spite of the anticipated increase in battery energy and power density, electric battery vehicle coverage will remain limited for the foreseeable future. So-called range extenders could increase this coverage, but these require a little more research. This is because a range extender must be simultaneously economical, light and easy to integrate into the vehicle. It also cannot cause any disturbances when implemented. DLR is developing a range extender using the free-piston linear generator (FPLG), which is precisely tailored to these requirements. And that's not all: with the FPLG, stroke and compression variability leads not only to a high level of efficiency at low emissions, but also allows operation using different fuels. Moreover, its extremely flat construction simplifies optimum positioning in the vehicle. Another highlight of this innovative motor concept is the replacement of the crankshaft with a combination of linear motor and gas spring. The linear motor creates electrical energy directly. This is converted or temporarily stored by the vehicle's electric motors when in forward drive.

The complete system was first successfully tested on the test bench at the end of 2010/beginning of 2011 in different configurations of linear motors, gas springs and combustion. In these tests, the forecasted performance parameters were confirmed without exception and, in some situations, exceeded them. An external evaluation of the FPLG went similarly well: the entire concept, work to date and future plans were assessed

very positively. The current objective is to implement the complete control technology concept for the ideal configuration identified and to also further optimise the two-stroke combustion process.

## VECTOR 21

### Simulated development of the vehicle market

Under the acronym VECTOR 21, DLR scientists have developed computer software to analyse the complex future passenger vehicle market. At the core of VECTOR 21 is a scenario model for vehicle technology that takes into account the most recent social, political, technological and ecological conditions in the German car market against the backdrop of global developments until 2040. The researchers have built up an extensive technology database over five years. It includes information on energy consumption, production costs and sales prices for different types of car and is constantly expanded. The bandwidth comprises conventional combustion motors, range extenders, battery and fuel cell propulsion vehicles as well as regularly updated descriptions of all technologies with regard to their development potential.

Different scenarios are created on the basis of the database on behalf of clients from politics and economics. In these, the computer model takes three factors that decisively influence the vehicle market as a basis. Firstly the clients, who are organised into different types of buyer from pro-innovation buyers to the innovation-shy and who can present a decisive hurdle for the market entry of technologies; secondly the different propulsion concepts and technologies competing for market entry over the next 30 years; and thirdly external factors such as tax, subsidies, CO<sub>2</sub> goals and developments in fuel prices. For example, the calculations are determined by the rate



of increase of crude oil prices until 2040, the share biofuels have in the overall fuel supply, the proportion of renewable energies and the price of hydrogen. If a contractor wishes to achieve a considerable CO<sub>2</sub> reduction within a vehicle fleet, the researchers can work out which technologies can be used to realise such a goal. Correspondingly, the scenarios are not forecasts, but rather models of possible future situations independent of the respective factors.

The rib was distinguished with the JEC Innovation Award at the JEC Composites international trade fair 2010 in Singapore. The fact that the rib is not only a component of an innovative concept, but that it also fulfils its stability requirements in practice has been proved in an initial crash test. This test was conducted at DLR's dynamic component test bed, which was inaugurated in June 2011. Large, complex passenger vehicle components up to the size of a car body can be tested for crash safety under actual conditions at the test bed.

## The Structure Stands

### Lightweight construction methods for electromobility

How can the car of tomorrow be made both lighter and safer? DLR researchers show how this is possible using rib and space frame construction. To this end they first developed a lightweight rib from carbon fibre composites (CFC). The term rib, which is common in aircraft construction, describes a load-bearing component that strengthens the fuselage. The rib is then built into a three-dimensional lattice known as a space frame structure. Simple geometric metallic structures that cancel out the high cost of the lightweight construction material are used here.

Although the rib is up to 35 per cent lighter than the comparative structure of a modern mid-class vehicle, due to its stiff-ring form it is perfectly suited to the high safety requirements of alternative propulsion concepts, e.g. for battery or fuel cell propelled vehicles. The markedly lower weight of the DLR passenger compartment of the future also has an immediate positive effect on vehicle energy consumption and, last but not least, benefits the comparatively heavy, electric battery vehicles.



The light rib, manufactured from carbon fibre composite



Support at the push of a button in the FASCar II

## Support at the Push of a Button

### More relaxed driving

Even today cars have systems that support drivers. ABS, ESP and park distance control are part of everyday life. However, DLR goes a few steps further. In Borås in June 2011 we demonstrated a perspective of what will be possible for mass production vehicles together with our EU HAVEit project partners. What is offered ranges from assistance in special situations to semi-automated and highly automated driving. The assistant option provides the driver with assistance only. For example, the steering wheel warns the driver with a slight twitch if they are in danger of leaving the lane. They still must steer themselves. In the semi-automatic level, the car assumes individual tasks from the driver. For example, with help of the intelligent distance regulation, the car automatically travels at the desired speed and, when doing so, keeps sufficient distance between slower vehicles in front. In the automatic level, on the other hand, the driver can even take their hands off the steering wheel; the car now automatically controls speed, distance and lane-keeping. However, responsibility remains with the driver. They decide themselves how much and what they wish to hand over to the car and can fully re-assume a driving task at any time. The system thus offers greater security and at the same time allows for more relaxed driving.

One of the test vehicles for the driving demonstrations in Borås was the DLR FASCar II, which is equipped with environmental sensors and a precise positioning system. It can thus recognise obstacles and objects and precisely register the driving lane. Even today, the FASCar II can independently look for a parking space on the test area or can be called

from the underground car park via smartphone. To date, highly automated driving has been designed for motorways, but in the next step it is to be extended to more complex environments, such as urban traffic. The fact that automated driving is fundamentally possible in actual urban traffic was first proved by the "Stadtpilot" project, in which DLR was involved.

Under the management of the Lower Saxony Vehicle Technology Research Center, the research vehicle Leonie kept in lane on the two-lane Braunschweig ring road at speeds of up to 60 kmh, took account of crossings, avoided obstacles and adjusted distance and speed to the traffic flow. It will take many more years until these types of technology find their way into everyday driving, but in DLR's research the future has already begun.

## Outlook

The overarching goal of DLR's transport research is a fast, reliable, safe and, at the same time, economically and ecologically sustainable transport system. To this end, we are researching and developing state-of-the-art technologies, concepts and strategies. We use our specific transport expertise to systematically access DLR internal know-how in the areas of aeronautics, space and energy for transport applications. As part of this we focus our energy on the programme's three research topics: terrestrial vehicles, traffic management and the transportation system.

Cars, commercial vehicles, trains, and locomotives of the next generation with lower energy consumption, lighter structures, optimised aerodynamics, increased safety, improved comfort and less noise are the focus of our research in this coming report year. We improve the effectiveness and efficiency of infrastructure utilisation with innovative approaches to



managing road and rail traffic as well as shipping and airports. Our contributions to traffic management for public mass events and disasters support police and emergency services. An integrated view of traffic development and the environment will allow us to follow new paths in researching transport system interactions. Furthermore, we will devote our particular attention to three issues: electromobility, mobility in the cities of tomorrow and maritime transport technology.

We are currently condensing the many years of dynamic transport research focussing on electromobility into a systematic approach. Nine interdisciplinary DLR institutes have merged to intensify already existing transport research on electromobility in a targeted manner and supplement selected complementary aspects in the areas of vehicles and assistance as well as markets and users with financial support from the Federal Ministry of Economics and Technology (BMWi). The focus is on increasing the acceptance and use of electromobility by extending the coverage and identification of further user requirements and their consideration in research as well as implementation. Our aim is not to tackle electromobility in all its facets within DLR. However, we are convinced that our ability to penetrate the entire relevant research spectrum within DLR is just as important as it is unique in German electromobility research. It also allows us to consider the research results of others as integral. We wish to further exploit this potential to contribute to Germany becoming a leading provider and leading market for electromobility.

With mobility in the cities of tomorrow, we have taken on another overarching issue of great complexity. Our task thereby is to take into account the interaction between traffic and town planning options as well as the transport system in an integrative approach and thus

**Transport: Revenues in millions of euros**

	2010 actual	2011 planned	2012 planned
Basic funding	31	35	40
Third-party financing	12	18	20
<b>Total revenues</b>	<b>43</b>	<b>53</b>	<b>60</b>

find new mobility concepts. This is becoming more and more important to us, as over the past several years, metropolitan regions in which cities and greater urban areas combine have been emerging in Germany as well as the rest of Europe. Manifold, often new functions that are incorporated into global structures are concentrated here. At the same time, the differences between areas in equipment and attractiveness are increasing. Changes in terms of spatial structure create new requirements in both passenger and commercial transport that the range of public transport, which has a long-term tie to the infrastructure, is increasingly less able to satisfy.

The exploration topic of maritime traffic technology will be evaluated by a group of experts at the end of 2011. There will be a concluding decision on the long-term acceptance of the topic into the transport programme portfolio.

**Expected revenue for the year 2011**

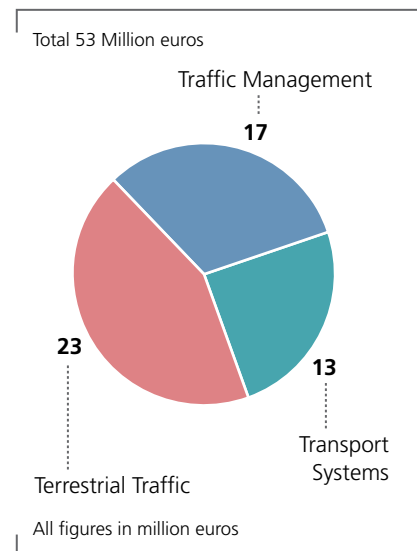



# Energy

The generation, conversion and use of energy are with us every day and play a central role in most technological systems. Even on a social and political level, the topic of energy has been pushed into sharp focus by the Fukushima disaster, volatile prices as well as environmental and climate risks. The energy concept and the German Government's 6th Energy Research Programme as well as DLR's pilot studies pave the way for a sustainable energy system, which cannot lastly be achieved with help of energy research.

To reach these energy goals three lines of action must be pursued simultaneously: energy demand must be drastically reduced through increased utilisation efficiency, energy conversion for the provision of electricity must become more efficient and ecologically sustainable and renewable energy sources must be comprehensively developed. At the same time, the energy supply system must be guaranteed within the overall system, e.g. through the use of suitable storage and regulation technologies.

All DLR research focus areas contribute – with different intensities – to these energy goals. In its energy programme DLR concentrates on the environmentally friendly, efficient, and cost-effective provision and storage of energy on a scale relevant to the energy industry; it is thereby in complete accordance with the 6th Energy Research Programme. DLR energy research deals with the topics of efficient and environmentally friendly provision of electricity, thermal, electrochemical and chemical energy storage and analysing and developing the overall energy system.

DLR energy research can gain competitive advantage from the breadth and diversity of DLR institutes' competencies. Firstly, these allow complex issues to be treated in a multidisciplinary manner; secondly, diverse synergies between these programmes can be exploited. Last but not least, test facilities, measurement methods and simulation processes can be shared.

On the basis of the success of their work in term of content and in addition to the basic funds available, DLR energy research is acquiring comprehensive external funding; approximately half from public funding programmes and industry. Both a clear application orientation and a solid scientific anchoring have a very positive effect here. However, the level of third-party funding achieved has led to the fact that the margin for exploring and opening up new fields has become very small.

## KONTAS

### The parabolic collector test bench

In 2010, KONTAS was built on the Plataforma Solar de Almería and comprises a rotatable platform on which a collector module up to 20 metres long can be installed. The precision test bench is an expansion of the Test and Qualification Center for Concentrating Solar Technology (QUARZ) and can be implemented to qualify a wide range of components of parabolic collectors. Using biaxial tracking, the test bench is very flexible with regards to the angle of solar radiation. To provide tempered thermal oil it has a heating and cooling unit, which is also installed on the platform. Temperature regulation of the thermal oil is made possible by quickly adjusting stationary operating points within a wide temperature range of 20 to 400 °C. There are plans to further improve the measuring accuracy of the test bench by, for example, precise definition of the thermal oil's effective heat capacity.

## Rig250

### Test compressor for gas turbines

The Rig250 multi-stage axial compressor successfully passed a programme of extensive testing at the DLR Institute of Propulsion Technology. The test compressor represents the front stages of a next generation stationary gas turbine and the transonic front stages of an aircraft gas turbine.

The effectiveness of housing components on increasing the working area for multi-stage axial compressors in combination with adjustable stators was first investigated in experiments together with



Rotatable parabolic trough test bench on the PSA

Rolls-Royce Deutschland and ALSTOM as part of an AG Turbo project. Detailed measurements with high temporal and spatial resolution – funded by the Aeronautics Research Programme IV – served the deep understanding of the complex flow processes, particularly the interaction between the adjustable front stator, the first stage rotor and the housing components. Over 700 measuring points (pressure, temperature, hot-film probes, strain gauges) were measured. The preparation with extensive numerical simulations allows for the time-consuming and expensive measurements to be reduced to the absolute minimum.



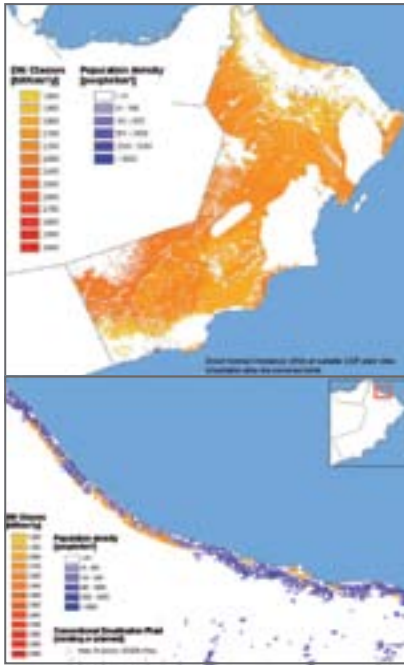

Potential chart for solar thermal power plants

The present data are now being analysed in order to draw conclusions for the future development of gas turbine compressors. Furthermore, the institute will use these results to validate all flow calculation and compressor layout methods.

This research provides exceptional proof of the synergies between DLR programmes and its close cooperation with industry.

## Sea Water Desalination

### Potential solar thermal power plants

In October 2010, together with the engineering firm Fichtner and the consultancy firm FutureWater, the DLR Institute of Technical Thermodynamics in Stuttgart was commissioned by the World Bank to conduct a detailed investigation into the potential of solar thermal power plants for sea-water desalination in the Middle East and North Africa (MENA). In the first phase of the project the technological concept of such stations was defined and a detailed performance model developed for testing technical and eco-

nomic feasibility at various locations. Furthermore, the available radiation and surface resources for such stations were calculated with the help of a geographic information system (GIS).

The new scenario of a sustainable water supply by 2050 generated from this data includes possible effects of climate change and a detailed investigation into the temporal correlation of supply and demand for all countries in the region. The second phase began in April 2011 in which locations for the first pilot facilities in the region were identified.

## enerMENA

### Solar know-how for North Africa

As part of the German Foreign Office funded project enerMENA (Energy in Middle East and North Africa), agreements on technological cooperation in the field of solar power plant technology were concluded with universities and institutions from Morocco, Tunisia, Algeria, Egypt and Jordan. Furthermore, two meteorological stations were installed in Jordan and Tunisia in order to build a reliable meteorological database for the region. The construction of six further stations in Algeria, Egypt and Morocco is being planned.

In autumn 2010, 25 engineers and experts from partner countries took part in a four-week capacity-building course in Almería. DLR scientists imparted technical expertise on how to independently plan, construct, operate and optimise solar power projects. The participants were selected on the basis that they were in a position to pass on the knowledge gained during the course to their colleagues. DLR also offers other compact courses on site.

## Institute of Solar Research and DLR Solar Tower

### Expansion of solar competencies

In 2011 the impressive success of solar research in recent years was supported by two important markers. The DLR Institute of Solar Research was founded in June. It is here that DLR is combining its many years of experience and leading international competence in the field of concentrated solar thermal power plants. It is being jointly lead by Prof. Pitz-Paal and Prof. Hoffschmidt and is being further strengthened by new colleagues who, like Prof. Hoffschmidt, have joined DLR from the Solar Institute of the Aachen University of Applied Sciences. At the new institute around 100 employees are working on methods and technologies that create electricity, fuels and process heat from concentrated sunlight. The federal state of North Rhine-Westphalia is expected to provide the institute with funds of approximately 27 million euros over the next five years.

At nearly the same time as the founding of the institute, DLR was able to assume control of the solar tower power plant in Jülich from Stadtwerke Jülich GmbH. This new facility will allow the scientists to work much more intensively on the development and testing of new components, make solar power plants more efficient and cost-effective, and research the creation process of solar fuels.

## TEG Line

### A complete development chain for thermo-electric generators

At the end of June 2011 the new "TEG Line" research facility was inaugurated at DLR Cologne. With the help of this major investment the DLR Institute of Materials Research will in future be able to promote the further development of thermo-electric materials and generators (TEG) under ideal conditions. Thermo-electric materials can transform heat directly into electrical current. Part of the waste energy that is lost to the environment in large amounts by computers, cars and industrial processes can be used as electrical energy with the help of such TEGs.

The TEG line offers the considerable advantage of assembling under one roof the complete development chain from powdery basic material to characteristic and analysis methods to the creation of the TEG module together with its testing and qualification.

The SkutMat project, in which the near-industrial production of highly efficient material known as skutterudite is being developed, can also be classified under this heading. Even for other research projects such as the BMWi-Project High-TEG, the TEGline represents an excellent basis for R&D work.

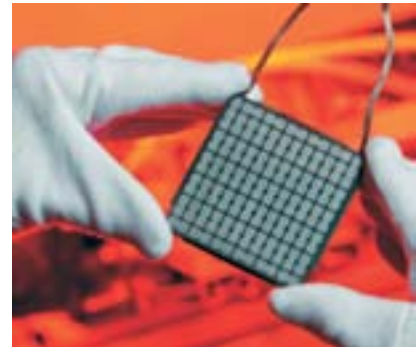

TEG module





Demonstration combination storage system comprising concrete solid matter storage system (left) and latent heat storage system (right)

## Helmholtz Institute Ulm

### Developing high-energy battery systems

In January the Helmholtz Institute Ulm (HIU) began its work on battery research in cooperation with DLR.

Efficient battery systems for the energy supply and mobility of the future are to be developed at the HIU, which is to grow to 80 scientists. The institute is supported by the Karlsruhe Institute of Technology (KIT) and the University of Ulm in cooperation with DLR and the Centre for Solar Energy and Hydrogen Research Baden-Württemberg (ZSW). DLR is financing a working group dedicated to the theoretical description of electro-chemical processes in batteries. These activities are affiliated to the DLR Institute of Technical Thermodynamics in Stuttgart. The focal points are the development of next generation high-energy battery systems (lithium-sulphur and lithium-air batteries) as well as scale-independent description of electro-chemistry and thermal management in lithium ion batteries. The modelling allows a detailed view into the fundamental processes as well as the optimisation of cells and components.

## Demo Storage Unit for Water/Steam

### The world's only combination storage system

With the demonstration storage systems for the heat transfer medium of water/steam developed at the DLR Institute of Technical Thermodynamics the first cyclical investigations were successfully conducted. The combined storage system, which is unique worldwide, comprises a latent heat accumulator to generate steam and a concrete storage system for superheating the steam. The latent heat accumulator, which boasts a capacity of 700 kWh with 14 tonnes of salt, is a significant innovation. The phase change takes place at 305 °C. The storage system is charged with steam at 400 °C and 107 bar whereby the steam condenses at approximately 315 °C and thus melts the phase change material in the latent heat accumulator. To discharge, the system pressure is reduced so that the water evaporates at approximately 10 K under the melting temperature of salt and is finally superheated in the concrete storage system. So far, this creates steam temperatures of 360 °C. The latent heat accumulator successfully demonstrated the expected high maximum power of 700 kW. The aim is to successively raise the outlet temperature to 460 °C and run it at different levels. The results are necessary for further industrial development of this technology, which is to become part of a storage system for a demonstration power plant for direct solar steam generation.

## Pilot Study 2010

### Energy provision in Germany

In February the German Federal Ministry for the Environment, Nature Conservation and Nuclear Safety (BMU) published the Leitstudie 2010 (Pilot Study 2010) developed by the DLR Institute of Technical Thermodynamics in Stuttgart together with its partners, the Fraunhofer Institute for Wind Energy and Energy System Technology (IWES) and the Engineering Bureau for New Energies (Ingenieurbüro für neue Energien – IfNE). The study describes a quantity structure for the expansion of renewable energies (RE) as well as Germany's overall energy supply and derives the structural and economic effects. For the first time a complete dynamic simulation of the electricity supply was conducted. The proportion of RE in primary energies rises by just under 55 per cent in the scenarios up to 2050. Up to 85 per cent of electricity will then be generated from RE; in the heating sector the proportion is approximately half of demand. In traffic, too, the RE share (not including electricity) with 42 per cent of fuel demand is already notable. Calculated on the basis of systems analysis, the expansion of RE (electricity, heat and fuel) up to 2010 will, due to investment, accrue 71 billion euros in differential costs in comparison to the cost of fossil fuels. Assuming an increase in the price of fossil fuels, these will continue to rise to a maximum of approximately 200 billion euros by 2020. The positive economic effect of RE expansion will begin to show in approximately 2025. By around 2038 the differential costs accumulated by all RE since 2000 will be at zero and the "outlay" thus paid off. By 2050, supplying the economy with renewable energies will have already saved approximately 670 billion euros in comparison to a fossil fuel supply.

## Oxyfuel Combustion

### Technology for CO<sub>2</sub> separation

A new high-pressure test bench for investigating oxyfuel combustion processes has come into operation at the DLR Institute of Combustion Technology. Climate unfriendly CO<sub>2</sub> is to be separated from emissions in power plants using this technology in order to keep it out of the atmosphere through subsequent sequestration. Instead of air, the fuel is burned with a mixture of O<sub>2</sub> and CO<sub>2</sub>, whereby the CO<sub>2</sub> is recirculated from the emissions. This way the emissions will contain, next to CO<sub>2</sub>, only water vapour, which can be separated through condensation. The combustion properties of oxyfuel flames will be investigated on the new test bench under conditions typical of gas turbines and using optical and laser measuring techniques. Issues include the stability of the flames, emissions of pollutants and the thermal load on the combustion chamber. The basis for the design of combustion chambers for oxyfuel gas turbines will be derived from this. Our research partner in this project is the Norwegian research organisation SINTEF.

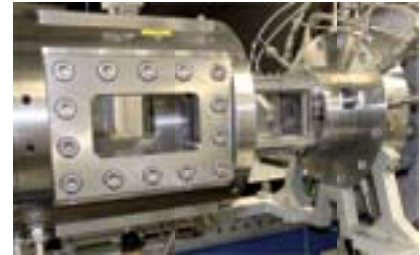

High-pressure test bench for oxyfuel combustion processes with optical access for laser measurements



Standardised temperature distribution of an air-fuel mixture containing hydrogen after self-ignition. The black lines show the limits of the flame zones.

## IVTAS

### Self-ignition simulation

As part of DLR's internal project IVTAS (Transient Combustion, Thermo-Acoustic Oscillations), a simulation calculation for self-ignition and flame propagation, which is unique worldwide, was conducted in a fuel-air pre-mixing zone at the DLR Institute of Combustion Technology. To this end a large eddy simulation (LES) method was paired with a combustion model that directly illustrated the ongoing complex self-ignition and flame propagation process with a detailed chemical mechanism. In the simulation calculation a test case was calculated and was also investigated in an experiment: a stream of hydrogen-nitrogen mixture is injected into a hot transverse flow and self-ignition occurs a long way downstream from the point of entry. This forms a central flame

that propagates in the mixing channel even against the primary flow direction and finally leads to the establishment of a stable flame. The processes observed in this experiment were successfully depicted in great detail in a numerical simulation. The DLR combustion code THETA was implemented as a platform for these calculations.

The overarching goal of the work of IVTAS is to improve and evaluate the forecasting ability of numerical processes for the simulation of transient combustion processes in low-emission gas turbine combustion chambers.

## Outlook

The optimisation of gas and steam turbines remains a central component of DLR's energy research. With the experimental and numerical work and high system competence, the efficiency of electricity generation can increase further and emissions can decrease – both in large-scale power plants and decentralised plants. The implementation of alternative fuels is also being investigated and prepared. Furthermore, in the long term a hybrid power plant with a gas turbine and a fuel cell system that promises great efficiency is to be realised.

Research into fuel cell systems will serve to improve their reliability and longevity for future use in energy supply. It is closely linked to work in transport research and aeronautics. The same is true of the development of thermo-electric generators, which generate electricity from waste heat. With materials that can withstand temperatures of up to 500 °C, DLR has achieved a unique position.

Concentrating solar technologies present the option of generating electricity in an efficient and environmentally friendly manner on a large scale. DLR covers a broad technical spectrum in this field,



from optimising the current parabolic trough technology to new designs for solar towers with innovative energy generation techniques. The Institute of Solar Research also works on application fields such as the generation of process heat, solar cooling, treatment of drinking water and hydrogen generation. In 2011 wind energy was again accepted into the energy research portfolio. The work focuses on the optimisation of the aerodynamic characteristics of wind power plants as well as forecasting tools and simulations of wind park characteristics to increase profits, and can hereby build on comprehensive competence from aeronautics.

DLR is meeting the dramatically rising demand for energy storage by expanding its research in the field of high-temperature heat accumulators, batteries and chemical storage systems. Like fuel cell systems, batteries demonstrate considerable synergy potential with transport research due to their versatile applicability. The goals of research in lithium battery technology are to increase energy density while simultaneously improving cyclical and long-term stability.

Finally, cross-disciplinary systems analysis aids the provision of policy advisory services and underpins the thematic orientation of energy research in DLR and HGF. They are in strong demand and financed by third-party funding, so there must be an expansion of basic funding in the coming years in order to increase the scope of action.

**Energy: Revenues in millions of euros**

	2010 actual	2011 planned	2012 planned
Basic funding	20	21	24
Third-party financing	33	38	38
<b>Total revenues</b>	<b>53</b>	<b>59</b>	<b>62</b>

**Expected revenue for the year 2011**

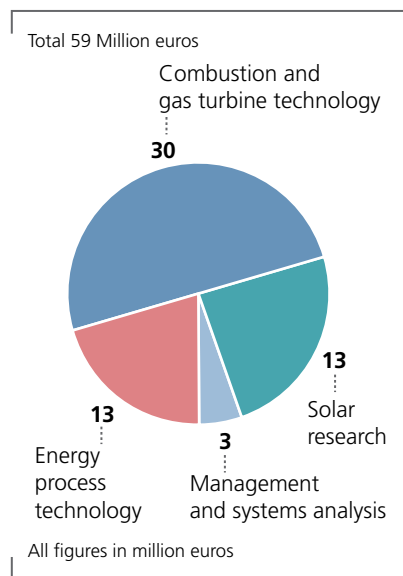



# Security

The Defence and Security programme of DLR plans and controls research and development activities relating to defence and security in coordination with partners from government, academia and industry. The cross-departmental area of Security and Defence links core competencies from the established DLR programmes: Aeronautics, Space, Energy and Transportation. In the course of these projects more than 20 DLR institutes and facilities contribute to developing, testing and evaluating technologies, systems and concepts and to the capabilities of security-relevant applications to be assessed and advised. In so doing DLR has comprehensive end-to-end system expertise in space and airborne platforms as well as expertise in significant system areas such as Earth sensors,

Earth observation and communications. With the available satellites and the associated institutions, data gathering infrastructures and numerous research aircraft necessary for their operation, the various recording and analysing methods and special simulation environments, DLR is in a position to contribute to the protection and monitoring of critical infrastructures for crisis and catastrophe management, border security and protection against terrorism and organised crime.

Furthermore, experience in the dual-use field completes DLR's core competencies.

DLR is networked into security and defence research on a national, European and global level. It supports Germany's position in European and international competition with its research activities. The strategic impetus of DLR's cross-departmental area of security and defence is delivered against a backdrop of future security and defence policy within Europe while, at an international level, it takes proper account of defined capability profiles aimed at protecting its population and safeguarding peace. The following results are examples from the interdisciplinary area of Security and Defence that were achieved in the previous year.



## Security at Mass Events

### Support from the air

Mass events like the Oktoberfest, the Love Parade, or demonstrations are often attended by people in hundreds of thousands. If something unforeseen occurs, the risk of uncontrolled panic is great. Such a mass reaction may be triggered by fires, detonations, or – as in the case of the Duisburg Love Parade in 2010 – simply by an extremely dense agglomeration of people.

Therefore, authorities and organisations responsible for security at mass events need to know approximately how many people are assembled in any specific location on the premises, the direction in which they are moving, and the density of each group. In most cases, however, only rough estimates of the total number of visitors are available from the police or the organisers. Frequently, such data differ widely, and they normally contain no information about local density anomalies. While surveillance cameras do show pictures of the situation on the spot, they do not deliver quantitative information about the number and density of persons in a large area.

As part of DLR's transport research VABENE project (traffic management for major events and disasters), the DLR Institute of Remote Sensing Technology in Oberpfaffenhofen has developed a 3K camera system capable of photographing from an airplane an area measuring 3 x 5 km within one minute. Its high spatial resolution (approx. 15 x 15 cm per pixel) permits head counts of individuals as well as of dense groups of persons. In addition, its temporal resolution of up to five images per second facilitates analysing movement patterns. Data is evaluated on board and transmitted to a ground station without delay.

The automated detection of persons greatly depends on the capability to distinguish individuals from the background and from areas of shadow. Based on a self-teaching approach, the software distinguishes between persons and other objects in the first step and categorises them as individuals or as part of a group in the second. The total number of persons in a group, and thus its density, is estimated on the basis of local variations in brightness and colour. The first attempts at events such as Rock am Ring demonstrated that the precision of the estimations of total numbers of persons was up to 90 per cent in the areas investigated.

## Helmholtz Research School on Security Technologies

### Training doctoral students in Defence and Security Research

Civil defence and security research is a cross-departmental area with extraordinary breadth. It stretches from natural and engineering sciences to the humanities to social sciences: Researchers from different subject areas work on a wide range of issues in this area. In view of its central importance, in 2010 DLR and the Technische Universität Berlin started a joint graduate school providing structured training in civil security research for doctoral students: the Helmholtz Research School on Security Technologies. It is the world's first example of a structured, interdisciplinary training programme for doctoral students in civil defence and security research. The programme is financed by the Helmholtz Association's Initiative and Networking Fund.

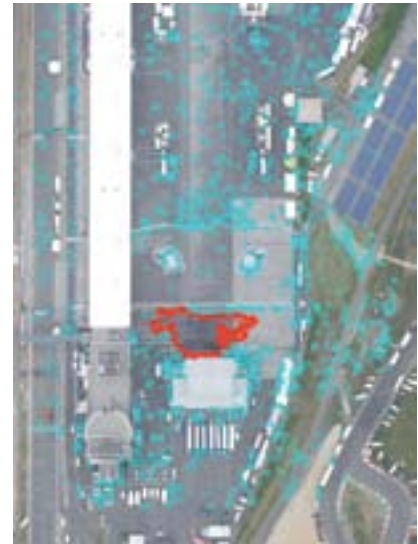

Aerial view of the premises of the "Rock am Ring" open air concert. Blue squares mark detected individuals; red lines mark dense crowds of people in front of the stage

The graduate school is coordinated by DLR. It came about at the DLR Institute of Planetary Research through the development of terahertz technology for security applications, which operated there as a spin-off from space research. Alongside the DLR Institute of Planetary Research DLR is involved in the college with its Institute of Robotics and Mechatronics (Department of Optical Information Systems).

Up to 25 doctoral students from Germany and abroad can undertake security research work at the Helmholtz Research School on Security Technologies. The students work in an interdisciplinary manner. Examples of research topics include holographic security codes, high-resolution cameras, optical navigation and applications of terahertz technology such as body scanners. Other doctoral work deals with social science issues in civil security. As well as the three-year specialist education, highly talented natural scientists receive training that prepares them for the job market and develops their personality. An integral part of the teaching programme is overarching aspects of defence and security research such as security processes and structures as well as the ethical, economic and legal bases and effects of

security solutions. The intention is that doctoral students are taught the many different perspectives of civil security through targeted cooperation with public institutions, end users and industry. The aim of the graduate school is to sharpen the consciousness of the graduates as regards the social dimension of civil defence and security research.

## Optimising Patrol Routes

### DLR know-how against criminals

The Braunschweig-Wolfsburg region is plagued by a growing number of car thefts. Most of these are committed by organised criminals whose professionalism presents a great challenge to the police. Optimised patrolling is intended to prevent thefts by deterring the thieves. So far, the police have been planning their rounds without support. This year, however, DLR and the Braunschweig police have initiated a project to support officers actively in planning their routes. For this purpose, the DLR Institute of Air Transport and Airport Research in Braunschweig developed the TAG (Touren Auswahl Generator – route selection generator) software. At present, the software is being assessed internally by the police, after which it will be tested on patrol service.

TAG generates routes and itineraries that are optimised to match the needs of the police, the objective being to deploy staff and patrol cars as efficiently as possible. Introducing random elements is particularly important in this context because it keeps criminals from recognising patterns to which they can adapt. Furthermore, the current day's occurrences must also be allowed for.

The TAG route planning software meets all these requirements. Its database, which is updated by the users themselves, contains the addresses of places with a potential theft risk. In addition to sites where cars have been stolen frequently before, the database also contains locations where valuable cars are often parked. All sites are given a threat index which reflects earlier police experience. Areas where the risk of theft is high are covered more frequently than others where it is lower. Moreover, some destinations are selected from the database by a randomiser. A cluster algorithm divides these into groups, and route-planning algorithms amalgamate them into route itineraries. What the TAG really does is generate a large number of small, optimised patrol tours. This approach permits the police to prioritise other missions against patrols. The events of the day and its emergency calls thus govern the timing of the patrols.

Beyond optimising patrol itineraries, TAG's uses are many and varied. If, for example, users want a particular property surveyed in order to prevent burglary, all they need to do is include the relevant data in the database. Moreover, the system may be used at airports where the premises and terminals are patrolled – a procedure that can be planned with the aid of the TAG.



Using TAG to generate efficient patrol routes

## Center for Satellite Based Crisis Information

### Satellite data supports emergency services

In order to overcome natural catastrophes and major accidents, emergency services and decision-makers in situation rooms need to be quickly informed about the crisis area. Earth observation can provide valuable data to this end through current, comprehensive and full-coverage crisis information. Examples from recent months include the mapping after the volcano eruption in Chile in June 2011 and the extensive mapping and damage analysis after the devastating earthquake and tsunami in Japan in March 2011.

In applied research projects funded through the DLR Space and Transport programmes, DLR develops algorithms to quickly and efficiently utilise satellite image data and geo-information to assist in crisis management and the provision of humanitarian aid.

In order to support the various phases of catastrophe management, the DLR Center for Satellite Based Crisis Information (ZKI) in Oberpfaffenhofen conducts research and development work so that it can contribute to early warning and risk assessment, support for acute crisis response and reconstruction. After a catastrophe immediate measures are supported with help of emergency mapping and accompanied by the planning and recording of the reconstruction. Current information on the extent of the catastrophe and damage analysis play an important role in this. Furthermore, the analysis of satellite data provides useful input parameters for compiling vulnerability and risk maps.

The analysis of the satellite data is conducted on behalf of national and international public agencies and aid organisations according to specific requirements. The ZKI is active within a German, European and international context and is closely networked with various government partners on a national and federal state level (crisis response centers, civil and environmental protection) and humanitarian aid organisations as well as satellite operators and space agencies. It was in such a way that the ZKI coordinated the contributions to the International Charter Space and Major Disasters mentioned in the Space Flight section.

A current example of the ZKI's implementation within the framework of this agreement is the tsunami catastrophe in Japan. Recording and data processing of current TerraSAR-X data regarding the affected coastal area began immediately after the devastating earthquake and the subsequent tsunami. DLR employees were deployed around the clock in order to map the devastated areas of the coastal region and provide an estimate of the extent of the damage. The results were delivered directly to the aid organisations and emergency services on site.

The continued development of this field through high-quality research and development is also one of DLR's focal points.

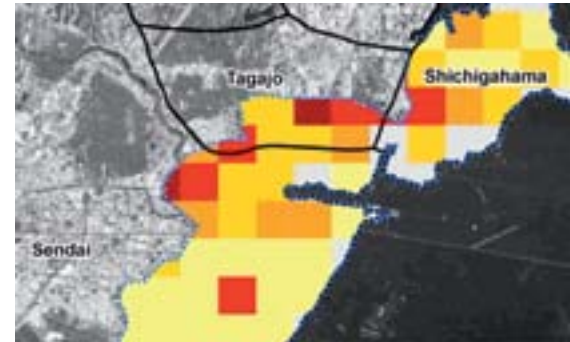

The rapid and large-scale mapping of the extent of the damage in the coastal area affected by the tsunami in Japan in 2011 was based on satellite picture data from TerraSAR-X and RapidEye





# Project Management Agency

## Project Management Agency for Aeronautics Research

### **Long-term funding of aeronautics research**

The Project Management Agency for Aeronautics Research (PT-LF) supports the Federal Ministry of Economics and Technology (BMWi) in implementing the German Aeronautics Research Programme (LuFo), as do the states of Bavaria, Hamburg, Lower Saxony, Brandenburg and Rhineland-Palatinate, who complement the federal programme with their own development programmes and projects.

With its fourth call for proposals for the Fourth Aeronautics Research Programme, the federal government is continuing its high level commitment to civil aviation research, which has increased significantly in recent years. With additional funds to be assigned upon the fourth call for proposals, LuFo IV has now reached a total volume of over 800 million euros.

Through this programme, the federal government is providing a stable basis for sustainable research in the aeronautics sector and is enabling industry, as well as large-scale research facilities and higher education institutions, to advance their successful research work. With the rapid economic recovery of the entire sector after overcoming the crisis of the previous year, sufficient resources will again become available to the research partners to take up new lines of development. During the report period, eligible projects have already been pre-selected for the next funding period from 2012 to 2015 in the course of an external evaluation procedure. These are scheduled to be confirmed before the end of 2011.

Like the federal government, the federal states were also able to stabilise their efforts in the area of aeronautics research. The federal state funding planned for the coming years has remained largely untouched by the effects of the crisis. The PT-LF manages the vast majority of regional aeronautics research activities in the federal states of Bavaria, Brandenburg, Hamburg, Lower Saxony and Rhineland-Palatinate.

The aeronautics research activities of the federal government and the federal states are integrated into the European Framework Programme for Research.



In order to ensure coordinated activities at regional, national and European levels, PT-LF has, on behalf of BMWi, assumed the role of national point of contact for the field of aeronautics research in the 7th EU Framework Programme for Research.

Due to the technological skills acquired through the federal and state aeronautics research programmes, German companies and research institutions are highly sought-after partners in European research consortia.

It was therefore possible to maintain the high return flow of funds from the European Framework Programme to Germany at over 20 per cent at the beginning of the 7th Framework Programme for Research.

A contributing factor was the ERANet "AirTN-Air Transport Net" EU project managed by the PT-LF as a coordinator, where initial cross-border research associations have meanwhile been formed in order to specifically combine expertise from the various member states and make it mutually available in the respective national programmes. Within AirTN, LuFo and its Austrian sister programme TAKEOFF occupy a pioneering role in the cross-programme cooperation. Common research associations are now regularly planned and started. As with the previous calls for proposals, the fourth call for proposals also plans transnational activities within LuFo and TAKEOFF. This tried and tested cooperation between two established aeronautics research programmes is a significant result of work within AirTN and could provide an example for further transnational cooperation in the field of aeronautics research.

**Project Management Agency Aeronautics Research:  
Revenue and funding budget in millions of euros**

	<b>2010 actual</b>	<b>2011 planned</b>	<b>2012 planned</b>
<b>Revenue</b>			
Third-party financing	3	4	5
<b>Funding budget</b>			
Federal Ministry of Economics and Technology	104	140	145
Ministry of Economics Free State of Bavaria	10	19	16
Ministry of Economics Brandenburg	2	2	2
Ministry of Economics Hamburg	3	3	1
Ministry of Economics Lower Saxony	7	16	18

As Project Management Agency for BMWi, the PT-LF has been able to consolidate its central role as a service provider and source of knowledge in the area of aeronautics research at EU, national and regional levels and is therefore in a position to effectively support BMWi in its efforts to provide coordinated and efficient support for aeronautics research in Germany and to prevent duplicate funding. This special role is unique among comparable institutions in the European partner countries.

## Project Management Agency in DLR

The Project Management Agency in DLR, PT-DLR for short, has positioned itself as a specialist provider of services in the areas of research and education funding and Project Management. PT-DLR operates at both national and international levels. Its clients include the Federal Ministry of Education and Research, the Federal Ministry of Economics and Technology, the Federal Ministry of Health, the Federal Ministry of Family Affairs, Senior Citizens, Women and Youth, the EU Commission, state ministries and various private entities.

At the end of 2010, PT-DLR employed approximately 750 people and managed to reach a level of approximately 950 million euros in research funding; this represents an increase of approximately 15 per cent compared to the previous year (cf. table). In 2010, a total of approx. 7,700 projects was sponsored.

The range of subjects represented by PT-DLR portfolio is extraordinarily broad and covers the majority of today's most important scientific and technological areas of interest. They include health research, environmental research, sustainability research, information technology, new media in the economy, research into the development of work and services, as well as education research and gender research. The Project Management Agency also incorporates the national contact points for EU programmes and the European research initiatives COST and EUREKA, as well as the EU Bureau of the Federal Ministry for Education and Research (BMBF). The International office of BMBF at PT-DLR oversees international cooperation in research and education in all regions of the world. The public auditors of the Federal Ministry of Education and Research for projects co-financed by the ESF are also part of the Project Management Agency. Due to its many years of experience in the areas of research and education funding as well as Project Management, PT-DLR maintains excellent contacts with research agencies and institutions, professional committees and proven experts in the national and international research community.

In 2010, PT-DLR was again able to further strengthen its position as Germany's largest Project Management Agency for research, development, education and innovation and was able to expand successfully. The Project Management Agency in DLR provides technical and specialist expertise in order to support

Funding planning: Revenues in millions of euros

	2010 actual	2011 planned	2012 planned
Third-party financing	71	80	82
of which are Project Management tasks	33	45	46
of which are special projects	38	35	36
<b>Funding budget</b>	<b>948</b>	<b>1,025</b>	<b>1,030</b>

their respective clients in making Germany fit for innovation. They do the same at international and EU levels, as both the internationalisation strategy of the Federal Ministry of Education and Research and the significance of the European dimension for Germany have substantially gained in importance in the last year.

The support that PT-DLR has provided and will continue to provide for the High-Tech Strategy of the federal government and the various comprehensive programmes in education goes almost without mentioning. That this often involves breaking new ground has presented significant challenges to PT-DLR, as has the “marketing” of educational offerings and research results in all fields of research. It should also be emphasised that, following its successful organisation of the “Year of Science 2010 – The Future of Energy”, PT-DLR has received a further follow-on request from BMBF and is organising the “Year of Science 2011 – Research for our Health”.

A detailed description of PT-DLR programmes and our work can be found in our annual report for 2010, available from [www.pt-dlr.de](http://www.pt-dlr.de).

**Allocation of budget resources 2010**

	<b>Number of projects</b>	<b>in thousands of euros</b>
Health Research	2,046	264,100
Information Technology	1,684	213,000
Environment, Culture, Sustainability	1,260	126,800
Development of Work and Services*	709	46,800
Education and Education Research	615	70,900
New Media in the Economy	426	97,000
Gender and Equality	389	25,100
Humanities and Social Sciences	229	38,400
Integration*	217	22,900
Eurostars	89	6,170
Innovation-Orientated Research	37	9,200
Years of Science Bureau	27	7,900
International Bureau	10	20,100
<b>Total</b>	<b>7,738</b>	<b>948,370</b>

\* Co-financed with funding from ESF (European Social Fund)





JAHRESLUFTVERSAMMLUNG  
2010

DLR





# ECONOMIC DEVELOPMENT

# Future Development of DLR

At the end of 2010 appropriate action fields, or key points, were identified based on DLR's general focus. The following specific strategic goals were derived from this:

- To strengthen scientific excellence
- To enhance horizontal communication between sites
- To contribute DLR's specialist skills to the world of universities and raise DLR's profile among students
- To introduce consistent principles for central processes
- To provide operational support and appropriate infrastructure
- To position DLR as a source of technology in business
- To optimise cycles by reducing practical difficulties and increasing responsiveness within DLR and to external events
- To step up cross-institutional/programme activities and combine external and interdisciplinary approaches
- To take a proactive, shaping role in European and international networks

Once results-oriented criteria had been defined the Executive Board agreed on measures for achieving these aims. A project was launched to implement each of these strategic goals.

For DLR, employee knowledge is a key component, be it generating new knowledge, documenting existing knowledge or sharing it with others. "Knowledge for Tomorrow" – this is the goal DLR aspires to reach.

For this reason, two further strategic goals were added to the list above in the spring of 2011:

- To establish an overall internal knowledge management system
- To introduce a consistent form of Project Management

Projects to achieve these strategic goals are already up and running.

One development at DLR is the constantly improving mapping of organisational processes. DLR strives to achieve a balance between adopting an organisational structure based on hierarchies and an operational structure where processes are managed by designated individuals. The aim is to increase speed and to minimise friction by optimising existing processes. This is having a direct impact as reflected in the ongoing optimisation of management processes. Following another successful audit of processes within DLR's administrative system, it was decided to subject management processes to a process of optimisation as well.

## Third-party Funding

Over the 2010 financial year a further increase in third-party funding of 19.9 million euros was seen compared to 2009. With a result of 401 million euros, third-party revenues now constitute 54 per cent of DLR's total budget. In addition to a renewed rise in third-party business, this can be attributed to the fact that institutional funding has been reduced as a result of special financing by BMWi being cut back.

The increase in third-party funding mentioned above is primarily based on the positive development in direct federal and state project funding. Projects to expand sites that are in many cases funded by individual federal states are contributing to this positive trend, as is a rise in project funding at federal level. In the year under review an increase of 58.1 million euros in federal project funding was achieved. The federal economic stimulus package in particular contributed to the positive overall result in the area of project funding.

German Research Foundation (DFG) projects with domestic research institutions and universities remain largely unchanged on the previous year.

When it comes to federal and state contracts in 2010, the volume of revenue was largely the same as in 2009. Revenue from cooperation with domestic commercial enterprises declined from 87.8 to 82.7 million euros. The EADS Group is the biggest client. Other key clients include Siemens, OHB, Kayser-Threde GmbH, Rolls-Royce, Lufthansa and Deutsche Flugsicherung.

By comparison, the proportion of revenue from foreign clients (volume of revenue) was broadly maintained at the same level as the previous year with orders from foreign, state-owned enterprises rising.

Third-party funding	2008	2009	2010
Total third-party revenue	€ 308 m	€ 381 m	€ 401 m
Revenue growth in comparison to previous year, commercial revenue from domestic R&D activity	11%	12%	-6%
Proportion of revenue from third-party sources	51%	49%	54%
Proportion of revenue from foreign clients (volume of revenue)	21%	25%	24%
Success rate of EU proposals over the last three years (accepted/submitted)	46%	37%	36%
Revenue from EU funding	€ 19.7 m	€ 21.7 m	€ 22.6 m
Ratio of EU projects as coordinator vs. all projects	14%	22%	22%

DLR's involvement in international research based on revenue from supranational organisations, particularly the EU and ESA, remains at the same high level. Revenue from contracts and co-operation with ESA is unchanged on the prior year.

At 36 per cent, the success rate for EU applications is just one per cent down on the figure from 2009 and therefore broadly the same as in the previous year. This figure of 36 per cent represents an average over a period of three years. It shows that although less funding was approved in terms of quantity, the success rate remained constant. Revenue from EU projects was up by approximately one million euros to 22.6 million euros. This indicates that the funding for individual projects must have risen in recent years. The number of EU projects with DLR acting as coordinator is unchanged on the prior year at 22 per cent.

Research-related results	2008	2009	2010
Publications in peer-reviewed journals	442	577	654
Peer-reviewed publications in proceedings, books etc.	593	460	563
Presentations for scientific conferences, workshops and lectures*)	0.55	0.55	0.51
Appointments to universities	12	13	14
Lectureships	248	244	296
Diploma theses	384	396	487
PhD theses	94	105	85
Postdoctoral qualifications	2	4	1

\* per scientific associate engaged by the institutes and facilities

## Research-related Results

The quality of science is one of the most important criteria for DLR as a research center. Alongside the third-party funding procured, significant indicators of this are the scientific results that are made public in publications, presentations and courses. Their volume varies from year to year, attributable mainly to project work, staffing fluctuations and activities relating to proposals.

The appearance of a total of 1,217 referred publications in the year under review means that there was a significant rise on the previous year, with another pleasing increase being experienced in the number of journal articles. The trend that has persisted over many years of an increasing number of completed Diplom papers continues unabated. The number of PhD theses was however down somewhat.

## Technology Marketing

DLR recognised the importance of innovation to society and business at an early stage and has therefore linked processes associated with research and innovation, regarding its commitment to the innovation sector as both an obligation and an opportunity. As per its general focus, DLR sees itself as driving and shaping innovation and as a sought-after social, scientific and business partner. DLR is a strong voice and promoter of innovative approaches and ideas.

In this context, Technology Marketing serves as a bridge between the pillars of invention and innovations. Technology Marketing at DLR implements this approach from the initial idea through to bringing a product to market – from analysing market requirements through to marketing DLR’s expertise as part of joint product developments with relevant industry partners. As more and more DLR technologies are deployed in new methods, products and services, this raises DLR’s profile in business as well as its already strong position in the science sector. The facility is also concerned with supporting business when it comes to defining objectives and requirements of innovative development services.

With regard to technology transfer and creating added value for both DLR and industry partners, a core task for Technology Marketing is marketing DLR competencies in areas which are largely outside DLR’s four main R&D focuses (cross transfer). This is complemented by Technology Marketing’s support functions in the key areas of research when technology is transferred directly to the corresponding industry (transfer).

In recent years, DLR Technology Marketing has optimised structures, developed new and now proven and recognised market positioning methods, and estab-





lished and extended new forms of cooperation with business. An ideas management system has been implemented across the board at DLR. Thanks to the DLR portal for new ideas, the number of new product/service/process ideas more than doubled in 2010. Over 40 ideas were submitted by DLR employees for implementation as part of innovation projects.

Technology Marketing initiated a project to prepare for implementation of the DLR innovation campaign as an integral part of DLR's new overall strategy and implemented it in conjunction with the facilities involved. The aim of this project was to design a framework architecture for innovation with input from different management levels at DLR covering the policy, goals, strategy, portfolio, culture and climate, and responsibilities surrounding innovation. One of the key project tasks was developing objectives, strategies and activities to communicate DLR's innovation policy and successes both internally and externally, along with DLR's role as a technology provider and driver of innovation.

The project was approved by the Executive Board in mid-2010 and commenced in October 2010. The framework architecture on innovation was designed to interconnect various internal DLR activities around innovation and was noted with approval by the Executive Board in May 2011. DLR Technology Marketing was also tasked with communicating the system throughout DLR using a brochure, among other methods, and its implementation.

Due to its experience, methodological competence and leading role in the Helmholtz Association (HGF), Technology Marketing is increasingly finding itself in demand from external bodies. For

example, it is heading up a joint project entitled "Enabling Innovation" on behalf of a DLR project management agency to develop a kit of methods that will allow institutes and research institutions to self-evaluate their ability to innovate. Technology Marketing also coordinates the Central Innovation Programme for Small and Medium-sized Enterprises (ZIM) Innofaktur.net project for the Federation of Reinforced Plastics (AVK). To date, seven mid-sized companies who wish to boost the transfer of research findings to their future products have come together as part of this project under the direction of Technology Marketing.

#### **Examples of successful Technology Marketing**

The aim of the "Kunstvogel" project is to achieve a realistic systemisation of artificial substitute birds which can be deployed in practical tests. These substitute birds are to have similar physical properties to real birds and are intended for use in reproducible field tests by the European Aviation Safety Agency (EASA), the Federal Aviation Administration (FAA) or rail authorities. Contact with EASA and FAA as regulatory authorities, the International Birdstrike Research Group (IBRG), other testing institutions and aircraft, turbine and railway rolling stock manufacturers is in place, allowing cooperation to make artificial birds relevant and acceptable.

The main objective of the project on highly efficient endwall adjustments for axial-flow compressors co-financed by the Aeronautics programme directorate is to provide new design rules on end-wall profiling as a marketable product

for industrial use in compressor design. The outcome will be a detailed construction manual for applying the endwall profiling to the hub (rotor and stator) and housing (stator) of axial-flow compressors. These instructions will include the related formulas of profile length, profile depth, length of disruptor, depth of disruptor and relative position in relation to front edge, as well as the distance of the profile from the blade suction side and the position of the profile flank in relation to the cascade division. This enables customers from the aeronautics and process compressor sectors to incorporate profiling into compressors effectively under the given aerodynamic conditions.

The aim of the wildlife rescue "flying platform" project is to mount a commercial, high-resolution thermal imaging camera onto an octocopter as a central detection system in order to fly over grassland which is to be cut and detect fawns. There are already octocopters on the market that are GPS-controlled and



have camera-mounts that are fully automated and can swivel. Using the method described here it is possible to achieve a search width in excess of 20 m depending on the flight altitude and camera's optical system. Because the field only needs to be entered if a fawn is found, the grassland suffers less damage. In comparison with previous inspections, the new system has benefits with regard to being much higher from the ground and separating the search process from the mowing itself. The project will be carried out in conjunction with I.S.A. GmbH as industry partner who make a contribution and will obtain a licence if the project proves successful. I.S.A. GmbH is one of the 50 most innovative companies in Bavaria.

**Proprietary rights**

The field of proprietary rights and licenses covers building and maintaining the DLR proprietary rights portfolio and looking after all commercial marketing agreements, including the granting of licenses. The inventory of proprietary rights held by DLR now numbers around 3,100 (domestic and foreign patent registrations and patents including EP and PCT registrations), the highest level ever

attained in the history of DLR. With 265 registrations in 2010, around 18 per cent more invention disclosures were submitted than in the previous year.

The illustration shows that the number of domestic proprietary rights has been continually increasing over the years and now amounts to approximately 1,650 proprietary rights (patents, utility models and their registrations).

Each year the German Patent and Trademark Office publishes a list of the 50 most active patent applicants in Germany, and in 2010 DLR held 21st place (previous year: 28th). The most active patent applicants are Bosch in first place (with 3,477 patent registrations) and Daimler in second (with 1,917 patent registrations). Airbus comes 25th with 216 patent registrations and MTU Aero Engines 47th with 99 registrations. The only other research body to appear on this list is the Fraunhofer Society in Munich (in position 15). If however you look at these figures in terms of the number of people employed by the above, a completely different story emerges: seen this way, DLR (with around 6,900 employees) registered one patent per 28 employees in 2010, while Fraunhofer (with some 18,000 employees) registered only one per 48 employees. This ratio must surely count as evidence that DLR has the capability to significantly further the state of technology in its research areas.

**Licenses**

The granting of licenses in 2010 resulted in a turnover of around 4.2 million euros, putting income from licensing up approximately 300,000 euros on the level of the previous year.

**Company start-ups**

DLR supports spin-off companies originating from DLR institutes and facilities. Technology Marketing prepares employees keen to establish a start-up for indepen-

Proprietary rights of DLR in Germany and abroad

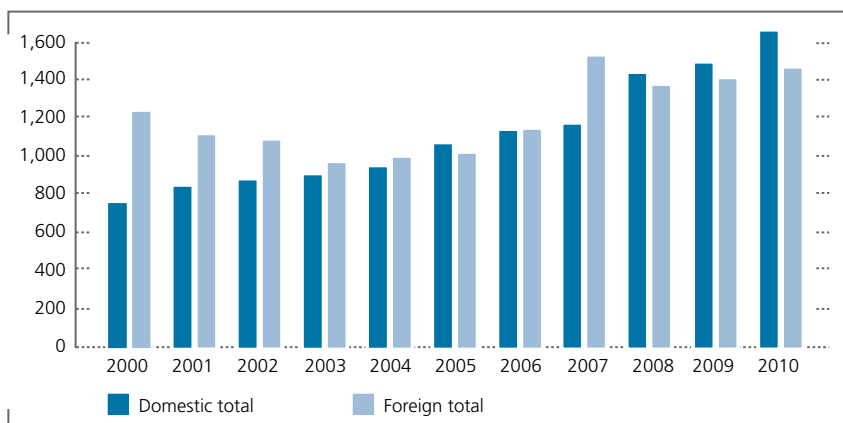

dence by providing appropriate advice on technology selection, development and helping them to design their business plan. With these young companies, DLR secures access to markets for its technology which it has not yet tapped into with its research findings. These companies are set up with licenses to use the technology and create applications in the form of profitable new products or services which, in addition to the licensing income expected in the long-term, may also in the short term produce third-party income for the respective institutes through R&D commissions.

Targeted agreement of projects with the institutes boosts the maturity of a technology and validates its use. For example, the documentation of R&D findings required to fulfil industry standards when gaining approval for a medical technology device makes a technology transfer from aerospace to medical applications at first possible.

Setting up a company also represents an attractive career option for the employees involved. Both the entrepreneurial activity and collaboration with a new company represents a forward-looking basis for career development, particularly from the viewpoint of staff on a fixed-term employment contract. Because the founders identify closely with the DLR technology, this boosts long-term skills retention for DLR at companies which are valuable cooperation partners.

Technology Marketing supports also DLR institutes and facilities in the preparation of proposals and the structuring of contracts with these companies covering collaborative work and licensing issues. This allows research findings to be used more efficiently and translated more quickly into added value. In the 2010 business year two further companies were established that draw on DLR technologies. One example is transferring optical communications procedures from

satellite technology to terrestrial applications, meaning that data in the field of security and traffic management can be transferred at unsurpassed quality, free from interference and tapping. To improve the operational reliability of wind turbines, sensor and measuring systems are being transferred from aeronautical systems engineering to guarantee that wind turbines are efficient and available. Experience of downtime on such wind turbines on land makes the deployment of such systems advisable, especially in the case of offshore facilities which are hard to access. With decentrally supplied electricity grids on the increase, this creates further opportunities for deploying proven technology from aeronautics.

The development of companies founded in recent years has been monitored, indicating that providing management support to new companies at an early stage proves invaluable over time. Consultants with experience of specific industries and business models work with the start-up team to develop the company in question into a competitive market player. This involvement often leads to lasting business angel relationships, which in turn considerably improve company competitiveness.



# Structure and Organisation

## Development of the Research Center

### Administrative infrastructure

In spring 2010 it was announced that, as part of a special initiative on the part of the Ludwig Erhard award, Administrative Infrastructure (AI) would compete with other organisations for the prize in an external evaluation. The Ludwig Erhard award is backed by the umbrella organisations in German business, the Ludwig Erhard Foundation, the German Society for Quality (DGQ) and the Association of German Engineers (VDI). Companies and organisations with a high level of organisational maturity are able to take part in the competition. The award is presented on an annual basis to companies that can demonstrate proven sustainable excellence and competitiveness. The competition comes under the auspices of the Federal Ministry of Economics and Technology.

As well as preparing a detailed prospectus to apply, entry involves a visit from a team of assessors. The seven assessors conducted in-depth interviews with a number of employees and managers in AI on-site over a period of six days.

This assessment proved so convincing that the assessors awarded AI third place in the mid-sized company segment. DLR is the first public entity to receive this accolade.

Others competing for this year's prize included leading companies such as BMW, Bosch, Daimler, REWE and Ricoh, the latter coming first overall.

This positive external evaluation as part of an ongoing process of improvement confirms the AI strategy of striving for business excellence based on the EFQM model (European Foundation for Quality Management), a path that the facility will continue to pursue in future.

Optimally positioned support processes in AI support core processes in research and help to improve the general conditions under which scientists operate. In addition to providing services of an appropriate quality, it is the aim of AI to optimise costs in such a way that the highest possible amount of funding from grant-awarding agencies is available for science. The success of this systematic focus on process optimisation is clear from the fact that AI costs and processes account for just 3.8 per cent of DLR funding.

### Technical Services

With Technical Services having conducted an EFQM self-evaluation for the first time in 2009, the STEP project which strives for excellence in administrative and technical infrastructure (ATI) processes was initiated in 2011. The aim here is to analyse the current state of excellence within Technical Services in order to lay the foundation for a joint ATI management system based on the EFQM model. The STEP project includes taking part in an external assessment of DLR Technical Services. The team of assessors is made up of both internal DLR assessors and external assessors who interview managers and Technical Services staff on-site.

The survey carried out in August 2011 focused on strategy development, processes, human resources development, plus communications and cooperation with customers, partners and suppliers. The results of the survey form the basis of the strengths and potential for improvement that feed into the external assessment report.

DLR Facility Management (FM) is aiming to achieve ISO 9001 and 14001 certification in quality management in 2013. Therefore, starting in November 2010, processes supporting the provision of FM services are being harmonised across DLR and all sites. Restructuring processes improves service quality and the ability to respond to customer requirements, as well as increasing operational productivity, all of which helps to secure jobs long-term.

When it comes to planning and constructing buildings and the technical systems required for scientific and experimental research, output and the associated outflow of funds has risen sharply in recent years and in 2011 will again exceed the previous year's level. Building management continues to be as busy as ever. Among other factors, this can be attributed to twelve construction measures that are receiving federal and state funding as part of the second economic stimulus package and which are scheduled for completion by the end of 2011. Construction measures completed in 2011 include a new workshop building and a laboratory building at the sites in Stuttgart and Bremen, the extension and refurbishment of the cafeteria in Bonn, completion of the first phase of the canteen in Cologne Porz and modifications to the wind tunnel in Braunschweig.

Work also commenced on some major new construction measures. As part of the competitive tendering procedure, qualified architects' offices and engineering companies were tasked with handling the following projects: the DLR Robotics and Mechatronics Center (RMC)



in Oberpfaffenhofen, space for the Institutes of Technical Thermodynamics and Technical Physics in Stuttgart and media supply in Cologne. All the chosen planners meet DLR's requirements with regard to quality, flexibility, efficiency and sustainability to the fullest extent, with sustainability issues becoming increasingly important on construction projects. Sustainable building is about optimising a building throughout its entire life cycle in terms of its consumption of energy and resources, environmental impact and overall economy – without overlooking socio-cultural quality. One new building is now being retrospectively assessed to see if it complies with criteria laid down by the German Sustainable Building Council (DGNB). The administrative building being planned and constructed in Cologne is also oriented around sustainable objectives. In this case, certification according to evaluation criteria on the sustainable construction of federal buildings is being sought in close cooperation with the regional tax office in Münster, the Federal Ministry of Transport, Building and Urban Development and the affiliated Federal Institute for Research on Building, Urban Affairs and Spatial Development. In addition the initiative on collaboration with DLR institutes focusing on energy research was continued. An analysis was performed to identify areas in which there is scope for greater networking, with the use of parabolic troughs in the air conditioning of buildings from the DLR Institute of Solar Research and heat accumulators from the DLR Institute of Technical Physics emerging as potential candidates.

Products created by the DLR Technology Systems House (SHT) include systems, system components and experimental equipment to explore and validate scientific questions which are designed to support the research activities of DLR institutes and facilities. Despite the highly

heterogeneous customer structure, a process organisation with clearly defined roles and functions maintains flexibility while standardising processes, interfaces and guiding principles. In some cases, the one-off items developed for DLR research divisions are exposed to extreme environmental conditions during studies and simulations. To fulfil such requirements, SHT utilises advanced construction, simulation and production methods. Working closely with manufacturers establishes a crucial edge in technological expertise in scientific equipment building. Setting up the DLR Rapid Prototyping Center SHT has resulted in new ways of producing prototype components fast based on digital design data. Development is focused on material development and research. One example is a research project on titanium aluminide – with the help of lasercutting technology – this proven new material can replace nickel alloys in gas turbines, for example, thanks to its low density and high strength properties. Other key areas of research are hybrid material combinations and material design for testing complex geometries. The Phoenix project sees wind tunnel models being produced for reusable European space transport systems with the help of lasercutting technology. The benefits of this method in the application of titanium as a material include the short time required to produce complex prototypes (for example, featuring extremely low wall thicknesses < 1 mm), which could not be made using conventional methods, as well as a reduction in costs.

Special attention is being devoted to the flight properties of the second DLR sounding rocket (SHEFEX II). The engineering task for the Technology Systems House is to advise on design and to optimise mass and flux when developing the structure of the rocket module. The Technology Systems House provides support for environmental testing (load, acceleration and frequency tests) and a very high level of quality assurance in addition to static and dynamic FEM calculations. Another addition is the creation of layouts from the draft stage to final plate by means of laser scribing. Laser processing overcomes structural delamination and vaporisation and enables, for example, the processing of copper-plated printed circuit boards and aluminium-coated films. This method enjoys greater reproducibility than current, solely chemical techniques.





Winners of the Visionary Projects competition at the final presentation with the Executive Board

### Science competitions within DLR

On an annual basis in planning, programme coordination considers the way new ideas and developments are taken up in research. Alongside this routine process, two different competitions are held within DLR on a regular basis to ensure the organisation remains at the forefront of research and development. For example, employees can submit medium to long-term ideas to an internal jury as part of the Visionary Projects competition, thus showcasing their creative potential. Young researchers in particular are encouraged to present their innovative and inventive ideas for the future with a time horizon of 10 to 15 years. First and second place are chosen via an internal selection process, with a research budget of up to 300,000 euros being allocated to research on these topics per year for two years. In the spring and following the implementation phase, the winners of the past call for proposals presented their results to the Executive Board and a small audience of interested young researchers. This launched ongoing debate and potentially laid the foundations for further work.

It is on the agenda for autumn 2011 to invite proposals for a new Visionary Projects competition.

While the Visionary Projects competition addresses future development and the ideas of individual employees, the DLR Center of Excellence (DLR CoE) competition recognises performance over the past three years by a group or institute. The title of DLR CoE comes with a research budget of 500,000 euros over three years. The winner is able to demonstrate technical excellence along with a highly relevant programme and leverages internal synergies effectively. Last year's award went to working groups from the DLR Institutes of Technical Thermodynamics and Combustion Technology for work on alternative fuels. The scientists involved performed particularly well on performance indicators such as their publication rate, patents, third-party revenue and doctorates. In terms of the relevance of the programme, outstanding scores on researcher exchanges, conferences and consultancy work ensured that the necessary requirements were met. At the end of three years, a previous DLR CoE concerned with robust, reliable communication at the DLR Institute of Communications and Navigation was awarded the right to bear the title for a further three years. An interim evaluation based on the selection criteria showed that performance indicators had again improved.

Both competitions are extremely popular and are certain to be continued over the coming years.

## Quality Management, Standardisation and Environmental Protection

### Quality management

Quality management – organising work processes systematically – is a given in industry but remains something of a rarity within a research institution.

As a Space Agency, research institution and Project Management Agency, DLR is the first and so far only institution to have pursued an overall concept for some years now whereby the Quality Board within the Executive Board provides a framework under which institutes and facilities organise their own subsystems in line with specific tasks and requirements. The minimum standard for the baseline system and subsystems is the international ISO 9001 quality standard for management systems. The baseline system was first certified back in 2003. External auditors monitor the effectiveness and development of processes annually. All subsystems across the board should qualify for certification by the end of 2013. The number of subsystems is currently 53.

By the end of the reporting period, 22 institutes and facilities had quality management systems. A further 17 institutes and facilities are in preparation. Growth of 10 per cent on the prior period has been achieved with a 74 per cent deployment rate (systems introduced and in preparation).

Going beyond the minimum standard, several subsystems have attained sector-specific certification such as VDA 6.2 (automotive) and ISO 13485 (medical devices), or have integrated other system standards such as OSHAS 18001 (occupational health and safety) or ISO 14001

Quality management	2008	2009	2010
Existing certifications and accreditations	25	28	30
Number of DLR auditors	15	10	11
Implementation of audits	32%	38%	49%

(environmental management). In June 2011 DLR Space Operations and Astronaut Training successfully added information security management in accordance with ISO 27001 to their integrated management system. This accounts for the figure of 30 for 2010 in the table above.

Where work processes call for it, inter-establishment management systems are introduced. For example, the Center for Combustion Technology is process-led in accordance with ISO 9001 via an inter-establishment system involving the Institute of Propulsion Technology and the management of the Cologne site. The system for Administrative Infrastructure is an inter-establishment system covering finance and human resources. The quality management system deployed by the DLR Earth Observation Center (EOC) is a cross-facility system for the Remote Sensing Technology Institute within DLR and the German Remote Sensing Data Center.

Accredited laboratories are operated at the Simulation and Software Technology facility and at the DLR Institute of Space Systems.

In the process of re-certifying EOC, ground control in the Antarctic was included in the scope of validity. The ISO 13485 re-certification audit for the DLR Institute of Aerospace Medicine in December was successful, as was ISO 9001 monitoring. Re-certification of the Space

Administration department at DLR, also in December, once again confirmed the management system's fitness. As expected, Administrative Infrastructure passed the first supervisory audit following its participation in the Ludwig Erhard award. The supervisory evaluation of the ISO IEC 17025 accredited software testing laboratory within the Simulation and Software Technology facility was completed successfully. In January 2011 the system at the DLR Institute of Flight Guidance was assessed with success. The transport programme was recertified in late February and initial certification of the energy programme was completed in April. There was confirmation of the systems associated with internal auditing and managing holdings, Technology Marketing and Quality and Product Assurance. In early March a supervisory audit of space operations was completed in accordance with ISO 9001 and OSHAS 18001, and in June initial ISO 27001 certification was also successful. The DLR Institute of Flight Systems and the DLR Institute of Communications and Navigation were also certified successfully for the first time.

Thus the quality management system ultimately serves to assure the quality of all DLR services and results. It creates common platforms for working with DLR's clients and partners, promotes collaboration, especially at the interfaces between institutes and facilities, and improves communication. For employees, it provides a transparent and reliable basis for working that also increases opportunities to learn from each other.

DLR is a member of the European Foundation for Quality Management (EFQM). The EFQM assessor training offered as part of the DLR internal training programme proved popular with employees over the past year. This year DLR again participated with an assessor in selecting the winners of the 2010 Ludwig Erhard award.

At DLR's New Year's reception in Berlin, the eighth DLR Quality Prize was awarded to the quality representative of the DLR Institute of Flight Guidance, the EFQM representative from Administrative Infrastructure and to the head of Technology Marketing, who is also site manager for Cologne and Bonn.

In 2010 93 per cent of the audit plan was completed. Virtually all the planned audits within DLR were carried out. There are 11 DLR auditors in total. Bringing on 40 trainee DLR auditors is a challenging task but an urgent necessity. This lays a

foundation that will enable staff to learn from one another on an ongoing basis. Every new auditor is a new source of inspiration and creativity, aiding the development of each individual subsystem.

The permanent working group of quality representatives now includes quality representatives from 95 per cent of institutes and facilities, actively contributing to development. This is where the design of the overall system and how frameworks and the individual subsystems interact are prepared ready for decision-making by the Quality Board, utilising the principle of countervailing influence. The permanent working platform of quality representatives also provides a platform for sharing experiences, learning from each other and promoting acceptance throughout DLR. During the reporting period, measures were initiated to boost the working group's effectiveness for mutual benefit and to involve institutes and facilities more closely in the design process.

The DLR process model approved in January 2010 is a prerequisite for a shared understanding of processes across institutes and facilities. Subsystems are linked into the DLR process model via management and support processes. Mandatory core processes across DLR are designed into the subsystems of institutes and facilities. In a similar way to central support processes, it is on the agenda to organise management processes systematically and mandatorily in a quality management system for the Executive Board.

## Standardisation

Competent standardisation work as a strategic Management Tool has achieved competitive advantages. In Germany alone, the economic advantages due to standardisation are determined as being around 16 billion euros per year.

Standardisation fosters global trade and international cooperation through rationalisation, quality assurance, environmental protection and safety. They contribute to deregulation by exonerating the state from technically detailed regulation. Standards play a major role in deciding the opportunities for bringing new developments to market and their positioning against European and international competition. They guide the transfer of knowledge and promote innovative potential and technology convergence.

DLR actively cooperates with the leading standards organisations on a national, European and international level, including DIN, CEN/CENELEC and ISO. Together with other European space agencies and partners to the European aerospace industries, DLR is compiling consistent standards for space flight projects within the European and international associations of ECSS, CCSDS, ESCC, EAQG, IAQG and ISO. More than 600 standards and over 1,000 specifications have already been developed and replace multiple national regulations.

The Federal Ministry of Economics and Technology launched the Innovation with Norms and Standards project in 2006 and the "Transfer of research and development results by normalisation and standardisation" project initiative, which focuses on research, in 2009. Back in 2007 and working with EADS Space Transportation and the Aerospace Standards Committee within this initiative, DLR successfully completed a technology maturity evaluation standardisation project, transferring it to a draft ISO standard in 2011. Standardisation of



research results within DLR is carried out alongside research and development work at the various institutes and facilities. It is coordinated and supported by the Standardisation department.

For the 2010 project year DLR received the go-ahead for funding for six standardisation projects:

- Expansion of up/downlink data structures in space flight for safety-related information
- Lightweight construction for railway rolling stock
- Qualification of optical components for concentrating solar power technologies
- Optical communications technology for data downlinks from low-flying earth survey satellites
- Digital speech communication / voice data structures – expansion of digital speech communications for ground stations in manned and unmanned space flight
- Identification of future needs for standardisation and research for the pan-European S-Band MSS system

Eight proposals for standardisation projects were submitted from the DLR Aeronautics, Space, Transport and Energy departments for the 2011 project year.

#### **Qualification of EEE components for space flight**

EEE components comprise both active and passive electronic, electrical and electromagnetic components (EEE) which during space flight are subject to particular demands on reliability, service life, vibration resistance, radiation resistance and temperature fluctuations, and must be qualified accordingly. EEE components represent as much as 30 per cent of the hardware costs for a space flight system. 50 per cent of the strategic components

whose functioning is key to the performance capability and reliability of space flight equipment or systems are manufactured in the USA and subject to US export restrictions. This leads to a significant constraint on the availability of EEE components in national space flight projects.

In a procedure harmonised at European level, DLR, within European Space Components Coordination (ESCC), is compiling joint standards and specifications for the qualification, procurement and use of EEE components in space flight. The department for EEE component qualification defines and implements the national technology development and qualification programme for EEE components on behalf of the DLR Space Administration department. Components are developed and qualified together with national component manufacturers. Thus, in collaboration with European partners, it has been possible in recent years to reduce dependency on US exports from 70 per cent to 50 per cent. In order to increase the availability of EEE components, DLR collaborates with China, Russia and Japan. Qualification by a national assembly and test house allows suitable commercial components to be used. Appropriate studies also determine the suitability of new component technologies for space flight.

In 2011 DLR is conducting 11 evaluation and qualification projects in the EEE components department with a total budget of 2.4 million euros.

#### **Environmental protection and safety**

As a sustainably managed organisation, DLR not only researches with the interests of environmental protection and public safety in mind, it also protects the environment and employees as part of its activities. Commercial success, spare use of resources, preventing climate change and protecting employee health are goals of equal importance to DLR.

The integrated management system for quality, environmental/occupational health and safety used by Technical Services at DLR provides a foundation for ongoing improvements in process quality, employee and customer satisfaction and safety, as well as optimising environmental protection activities. It is based on ISO 9001 and ISO 14001 requirements. Safety-related aspects at DLR are being incorporated in accordance with OHSAS 18001 (occupational health and safety management system). The integrated management system is used to manage processes in order to implement organisational policy, achieve objectives

and to improve principles relating to quality, the environment and occupational health and safety on a continual basis. The system has been extended by EFQM, the Balanced Scorecard and a continual improvement process (CIP) as supplementary tools and by carrying out internal and external evaluations. An increase in the number of trained auditors will enable comprehensive audits to be conducted at DLR facilities and partners, such as waste disposal companies.

At Technical Services, the integrated management system was re-certified in 2011 by the external certifying body. This confirmed that Technical Services is already on the way to implementing corporate sustainability management (CSM) based on its environmental objectives and sustainable architecture concept. Workshops focusing on sustainability were held in order to find methods and technologies that will boost the efficiency

of building and equipment operation as well as energy distribution. DLR knowledge from research is an important element of this. In this way, DLR is making a contribution to the federal government's strategy on corporate social responsibility.

DLR Building Management gives high priority to the entire life cycle including energy-related, environmental and social factors. Sustainability within building management affects the planning and realisation of buildings and equipment, as well as the refurbishment of buildings.

This focus on life cycle and the ecological, economic and socio-cultural aspects of sustainable building has already resulted in some successes. These include refurbishing facades and roofs (adding thermal insulation and installing triple glazing) or fitting translucent roller shutters in aircraft hangers to reduce heat loss due to transmission. To generate heat, air-geothermal heat exchangers and energy-saving condensing boilers are being used. In total 10 per cent of DLR's gross floor area has already been upgraded to be energy-efficient. In addition all DLR properties have been tested according to fire safety requirements and risk-assessed. At locations adjacent to natural conservation areas, as in Cologne for example, multi-storey buildings are erected in order to reduce the amount of land used and therefore to lessen the impact on the natural environment. When purchasing machinery for DLR workshops (Technology Systems House), environmental and safety criteria likewise greatly influence decision-making.

An ongoing focus of work on safety and environmental protection is communications via IT media. To minimise work travel between DLR sites, video conferencing is increasingly employed. For this purpose a high number of conferencing systems have been set up in meeting rooms and at computer workstations which should help combat climate change by creating less traffic.

Legal databases and information systems are set up jointly with Helmholtz centres. This also applies to adding content. Bi-monthly newsletters on topics relating to safety, environmental protection and associated areas are frequently requested by functionaries within the Helmholtz Association (HGF). Managers and employees are continually made aware of environmental issues to encourage them to make responsible use of resources such as water and energy. This includes seminars for managers, instruction for specific target groups and special information events, such as healthcare days at DLR which are held with support from external occupational physicians.

Regular dialogue also takes place with both internal and external network and cooperation partners. To complement specialist expertise DLR maintains networks with universities, for example. The results of Master's projects commissioned and completed on safety-related and environmental topics and methods also flow into DLR representatives' safety and environmental protection activities.

In the field of risk communications, a crisis panel has been set up to coordinate issues such as pandemic planning and other safety-related and environmental measures pertaining to potential damage events and to provide timely information to employees and other target

groups. A related handbook is stored on the intranet and kits are available for use should a pandemic occur.

According to provisional figures from German Social Accident Insurance (DGUV, as of 31 March 2011), more notifiable accidents occurred in Germany in 2010 than during the previous year. Purely working accidents rose by 8.8 per cent and commuting accidents were up 25 per cent. Fatal working and commuting accidents increased by 9 per cent. Reasons cited for this were the economic recovery and the exceptionally cold winter with increased precipitation. The rate of working and commuting accidents per 1,000 employees will therefore be approximately 10 per cent higher Germany-wide for notifiable accidents than in the previous year based on internal projections, i.e. approximately 32 (2009: 28.5). Data from BG ETEM (Berufsgenossenschaft Energie Textil Elektro Medienerzeugnisse), the professional association with which DLR is insured, paints a similar picture. According to the professional association as of 16 May 2011, the rate rose by 9.53 per cent to 17.3 accidents per 1,000 insured persons.

By contrast, DLR was able to reduce its rate in 2010 to 7.5 accidents (see graph), thereby achieving a low rate which is well below comparative figures. Within the Helmholtz Association (HGF), performance indicators for large-scale research facilities have been generated and compared since 2008. There, the average rate per 1,000 persons is consistently low at approximately 10 accidents and therefore just above DLR figures this time. In 2010 there were a total of 52 notifiable accidents at DLR, almost half of which occurred not at work but during travel for work, en route between

### Accident trends at DLR

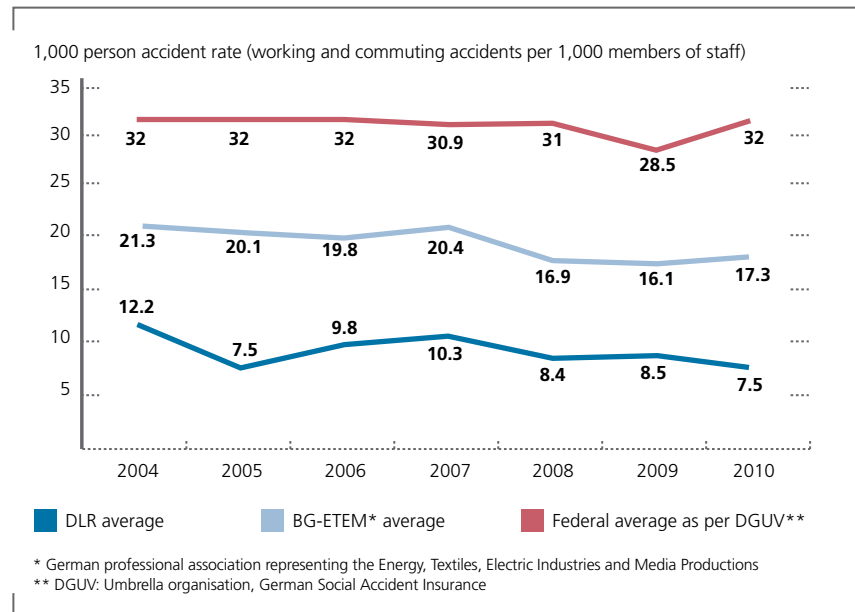

The BG ETEM average used was current at 16 May 2011 (taken from BG ETEM information online). The nationwide average for this indicator was not available at the time of preparing the graph. The figure for 2010 was projected based on provisional figures from DGUV published online as at 31 March 2011.

the workplace and home or in other areas that count as work-related such as corporate sports activities (25 accidents). There were no fatal accidents to report. Serious injuries involving an extended period off work were rare. The severity of accidents (days off per accident) was on average 16.5 days, down by half on the previous year. Here DLR was broadly in line with the HGF average of 15 days. The majority of working injuries were from falls, trips, sprains, cuts and puncture injuries.

# Partners

## Helmholtz Association of German Research Centres

### Developments in programme funding

DLR is involved in two HGF research areas. Within the Aeronautics, Space and Transport research field, all three programmes are implemented by DLR alone. Within the Energy research field DLR participates in programmes on renewable energies, efficient energy conversion and use, as well as technology, innovation and society. Implementation is in its third or second year respectively for programs with five-year durations.. Part of the increased budget agreed within the second research and innovation pact is being used to work on new topics. Under the aeronautics programme, research into multidisciplinary, numerical simulations of aircraft is being stepped up. Research into developing re-entry technologies extends the space portfolio. Within

transport DLR is addressing a very important aspect of electromobility by developing the next generation of rail vehicles (Next Generation Train project). Energy storage and the aerodynamics of wind turbines are being reinforced as topics in energy research.

## National Networks

### Collaborations with universities

Collaboration with universities is a strategic goal within DLR's corporate policy. Collaborative projects in almost every area of activity ensure the optimal utilisation of available resources in programmed research. Similarly the training of highly qualified new talent for industry and science benefits from working with others, creating a classic win-win situation. For universities, the DLR infrastructure available in scientific and technical areas is in many cases a prerequisite for a wide range of research projects, while DLR gains access to up-and-coming new scientists and new research topics.

In the scope of the Excellence Initiative, collaboration between universities and DLR is becoming increasingly important, yet at the same time the nature of cooperations is changing. The trend is towards institutionalisation with the aim of achieving greater networking which goes far beyond purely technical collaboration on joint scientific projects. Tak-

ing into consideration key subject areas at specific locations, DLR's collaboration with the Technische Universität Braunschweig, the University of Stuttgart and TUM (Technische Universität München) has already been strengthened and institutionalised. Within DLR, the DLR@Uni instrument establishes a framework for partnerships marked by content, which is flexible enough to incorporate both the diversity of content and the respective ancillary conditions within the cooperation. DLR@TU Braunschweig carries the name "Campus Research Airport" and focuses on the theme of aviation and traffic research. DLR@Uni Stuttgart has defined a "Research Campus" with the motto "Designing the Future Together". In Munich, a DLR proposal for closer cooperation resulted between DLR, TUM, the Universität der Bundeswehr and Bauhaus Luftfahrt forming a joint faculty known as Munich Aerospace, Faculty for Aeronautics and Space Travel, e.V. HGF funds these three location-related research networks as part of the Helmholtz DLR@Uni alliance. The collaborative approach of the Helmholtz DLR@Uni alliance is designed to expand research activities between DLR institutes and universities in a specific region in a strategic fashion in key areas of competence and to strengthen training at doctoral level in structured programmes.

Each year the institutes of DLR oversee around 750 postgraduate students working on their PhD theses, with another 450 students or so completing their final year theses at DLR facilities. The number of DLR scientists with lectureships has increased significantly in the last few years. In 2010 a record level was achieved of just under 300 lectures, tutorials, seminars etc. carried out at universities and colleges.





Combined appointments form a central element of the links that individual employees have to higher education. All heads of DLR institutes must also accept an appointment to a position in higher education, meaning that alongside their positions in the institutes, the DLR heads of institutes take on a university professorship with all the rights and duties to the university this entails. Increasingly, heads of department at DLR are also being appointed to combined positions. Combined appointments based on the qualification criteria of both partners ensure that positions are filled by the best candidate and give the scientist appointed more opportunities for research and teaching.

#### Participation in DFG programmes

Integration into the programmes of the German Research Foundation (DFG) is an important measure of the quality of DLR research work. DFG's "coordinated programmes" support extensive interdisciplinary networks of researchers dedicated to a broader range of topics. In special research areas, the focus is on excellence in research, priority programmes designed to develop pools of expertise, and research training groups for training high-calibre young scientists. During the reporting period DLR institutes participated in Collaborative Research Centers 19 times, Priority Programmes 15 times, and Research Training Groups 4 times, a marked increase on previous years.

National and European networks	2008	2009	2010
DFG participations	33	34	38
Sponsorship agreements	49	41	32

#### Sponsorships

Sponsorships are a successful instrument for rapid technology transfer through individuals and also enable highly qualified young talent to be secured for research and development in science and economics. This involves companies taking over half the costs for training young scientists who are engaged by DLR for a period of between three and four years. They work in areas of equal interest to DLR and the company. Naturally the individual concerned spends a portion of their time at the company itself. A total of 32 sponsorships were overseen within DLR in 2010. This represents a continuing downward trend, with the number of sponsored individuals reverting to the level in 2002 following a high point between 2004 and 2008.



## European Networks

### 7th EU Framework Programme for Research

In the completed calls for proposals for the EU's 7th Framework Programme for Research (FRP) at the end of 2010, DLR once again submitted numerous applications in the areas of transport (including aeronautics), space flight, energy and safety, enjoying above-average success. In aeronautics, for example, of the 19 proposals that DLR was involved in (acting as coordinator in 2), 15 received funding.

To date, DLR has proposed 715 projects under the 7th EU FRP, of which 286 have received funding. This makes DLR's average success rate around 36 per cent at present, significantly higher than the programme's typical success rate in the 7th round (approximately 20 per cent).

In parallel to the application process, DLR played an active role in preparing work programmes for proposals in 2011 (published on 20 July 2011). Through its participation in European technology platforms (ETP) (ACARE, ERRAC, ERTRAC), other European interest groupings (EREA, ECTRI, ERTICO, N.ERGHY, EERA) and joint technology initiatives (JTI), DLR was and continues to be significantly involved.

### Horizon2020 – 8th EU Framework Programme for Research and Innovation

In preparation for the next EU FRP (Horizon2020) the European Commission last year conducted mid-term review of the 7th EU FRP. DLR participated here both directly by virtue of its own position and indirectly via its collaborative role in position papers by European technology platforms and interest groupings.

DLR's main points are as follows:

- The 7th EU FRP supports the attainment of European research goals
- The FRP is fundamentally well executed
- There is a need to optimise the existing mix of tools and to take them further beyond the 7th EU FRP
- It is however necessary to simplify administration

These statements are taken from the report by the relevant expert group published on 17 November 2010.

Major differences from the DLR position are evident in the area of joint programming and international cooperation, with DLR being critical of their unrestricted use and expansion.

On 9 February 2011 the European Commission published its green paper entitled "From Challenges to Opportunities: Towards a Common Strategic Framework for EU research and innovation funding" (COM(2011)48) in preparation for the next Framework Programme. DLR again participated in the subsequent consultation, which was completed on 20 May 2011, by submitting its own position paper. In it DLR advocated that the Commission should cover the entire innovation process in funding and maintain the current, successful mix of smaller, mid-size and large-scale projects. In addition it is DLR's

view that the ACARE approach – jointly defining the European research agenda with individual responsibility taken for coordinated implementation – has proved successful. Because it is accepted by all parties involved, DLR proposes examining the extent to which this approach can be adapted to and adopted in other subject areas. DLR also proposes extending funding to large-scale facilities for industrial applications in the field of infrastructure.

Since President of the European Commission José Manuel Barroso adapted commissioner portfolios with the aim of ensuring that research and innovation serve EU policies more effectively, the specialist commissioners and the Directorates-General assigned to them are now responsible for research content, unlike under the 7th EU FRP. In line with this, Commissioners G. Oettinger (Energy), S. Kallas (Transport) and A. Tajani (Industry and Entrepreneurship) prepare their own position papers on research and innovation. With the Directorate-General for Energy reviewing the Strategic Energy Technology Plan (SET-Plan), for the first time the Directorate-General for Mobility and Transport is preparing a Strategic Transport Technology Plan (STTP) to present the basis for transport research in the next FRP (Horizon 2020). Hearings were organised in February and March 2011 at which organisations such as ACARE, EREA and ECTRI were invited to put their positions forward. Via its involvement in these organisations DLR was able to present its position as the STTP was being prepared. Similarly DLR is involved in the SET-Plan review through its participation in European energy research bodies like N.ERGHY, EERA or SOLLAB.

Parallel DLR has supported the cabinets of the respective European Commissioners by preparing contributions on priority research topics and conveying them to the Commission's services and German federal ministries.

On 29 June 2011 the European Commission presented proposals for the next multiannual financial framework for the period 2014–2020 (EU budget). As part of this approximately 80 billion euros have been earmarked for Horizon 2020. Research and innovation are also to attract greater use of structural funds. Over the next few years DLR will be actively engaged in ensuring that sufficient funds are available for DLR's research areas in the period from 2014 to 2020.

### EU Business

On 2 February 2011, at the invitation of the Chairman of the Executive Board Prof. Wörner and the State Minister for Science, Research and Art Prof. Frankenberg, DLR held its traditional New Year's reception in Brussels representing the state of Baden-Württemberg. This year's event focused on energy issues. Following an address by Ministerial Director Tappeser, representing the Minister, and Prof. Wörner to welcome the 120 guests, Director General Lowe of the European Commission outlined the EU energy strategy with focused, long-term action by the European Union in the field of energy research an urgent priority. The following three core areas are to be reinforced: lowering CO<sub>2</sub> emissions, reducing energy consumption and making greater use of renewable energy sources. The necessary technologies and infrastructure can only be developed if there is close cooperation between research, industry and policymakers. In response Prof. Wagner and Prof. Aigner presented DLR's multi-layered competencies in energy research and possible contributions towards attaining the EU's ambitious energy goals.

In the meetings that followed moderated by Prof. Wörner, representatives of DLR and the state of Mecklenburg-Western Pomerania discussed with MEPs, representatives of the European Commission and national ministries how the research and demonstration capabilities built up at the Rostock Research Port in the area of satellite-based marine safety could be incorporated more effectively into European policies and research activities.

The strong interest in discussions and events over the course of the two days once again showed that DLR is recognised as an important and expert dialogue partner in Brussels and beyond.

During a workshop prior to the DLR New Year's reception in Brussels, Prof. Wörner, Deputy Director General Weisenberg (DG ENTR) and representatives of BMWi discussed the EU's future commitment to space flight. There were then talks with the European Commission about Galileo and with Herbert Reul, the chair of the European Parliament research committee, during the late afternoon on European space policy.

In all talks DLR argued that successful implementation of the two flagship initiatives – Galileo and GMES – was the top priority during the EU's next financial perspective (2014–2020). In this context it was also agreed with the European Parliament to hold an information event regarding Galileo in particular in the autumn of this year.

On 7 April 2011 the European Commissioner for Research Máire Geoghegan-Quinn and the Minister for Science in North Rhine-Westphalia, Svenja Schulze, visited DLR in Cologne to find out about the latest DLR topics and competencies. As part of preparations for the next FRP (Horizon2020), there were also discussions with the Executive Board of DLR on European aeronautics strategy (Flightpath 2050), sustainable European energy provision and issues relating to research infrastructure in Europe. Both guests were enthusiastic about DLR and had particular praise for its involvement in national and European innovation processes (from basic research in partnership with universities to working with industry on product innovation).

## European Groups

### Joint technology initiatives

At the Clean Sky Governing Board meeting Prof. Henke was named Vice Chairman for 2011 to represent associated members. This takes into account DLR's important contributions to Clean Sky, particularly in terms of managing technology evaluators. The Clean Sky Joint Undertaking and the European Commission have also confirmed that associates may take part in calls for proposals issued by Integrated Technology Demonstrators in which they are not yet actively involved. That funding acquired in this way does not count towards the own budget, DLR is planning to apply to calls for proposals in the fields of propulsion systems, regional aircraft and eco design.

Within the Fuel Cells and Hydrogen Joint Technology Initiative (FCH-JTI) the application procedures and amount of funding in particular are hard to predict. For this reason FCH-JTI, the industry grouping and N.ERGHY (representing research) are working on harmonising procedures with those used in the 7th FRP and Clean Sky. Attempts are also being made to supplement direct financing of the joint undertaking with member contributions via what is known as a project contribution, putting this aspect on a broader and fairer footing.

### ACARE – Advisory Council for Aeronautical Research in Europe

After ACARE laid the ground with its Beyond Vision 2020 paper, at the end of 2010 the EU Commissioners S. Kallas (Transport) and M. Geoghegan-Quinn (Research, Innovation and Science) invited industry representatives and Prof. Wörner to participate in a high level group (HLG) on aviation and aeronautics research. With the support of a group of experts, the HLG has developed a new vision for aviation and aeronautics in Europe. Flightpath 2050 was presented to the general public at the 2011 Aerodays in Madrid by, among others, EU Transport Commissioner Kallas and Prof. Wörner.

To achieve the goals of Flightpath 2050 the HLG proposed further developing ACARE. In line with this proposal Vice President Siim Kallas hosted the first general assembly of the new Advisory Council for Aviation Research and Innovation (ACARE) in Le Bourget during the Paris Air Show. Terms of reference and the working structure of the new ACARE were determined. ACARE is thus tasked with preparing a new strategic roadmap for research and innovation in European aviation (SRIA) by the middle of next year. DLR in partnership with ASD (Association of European Aerospace and Defence Industries) as a partner of the NEARS (New European Aviation Research Strategy) EU Project successfully applied to support this strategy process on an organisational level.



### **EREA – Association of European Research Establishments in Aeronautics**

Following completion of the Air Transport System of the Future study largely worked on by DLR, ONERA and CIRA under the auspices of EREA, Mr. Peters as EREA Chairman presented the results at the ACARE Plenary Meeting on 23 November 2010 and in separate bilateral talks with Director Generals Ruete (Transport) and Smits (Research, Innovation and Science). In some areas the study was one of the key foundations of the Vision 2050 prepared by the HLG. It also formed the basis of the EREA contribution to the Strategic Transport Technology Plan.

In addition to work on content, Mr. Peters welcomed approximately 100 guests from the European Parliament, European Commission, industry, research and member states at the annual reception on 2 December 2010. Together with ACARE Co-Chairman Mr. Quentin, he presented the EREA Best Paper Award 2010 at this event to M. Meunier from ONERA.

Under the EREA umbrella, the executive boards of DLR, NLR and ONERA discussed further collaboration in the field of wind tunnels. The objective is to safeguard the ETW, DNW-LLF and ONERA-S1 wind tunnels long-term as they are strategic for Europe. Based on the successful EU ESWIRP project, the European Commission is planning to organise a workshop with EREA on 20 October 2011 covering the future handling of application-oriented research facilities or those used by industry under the 8th EU FRP (Horizon2020).

During the Air Show in Le Bourget, the EREA Board was able to discuss with representatives of the European Defence Agency the potential for future cooperation, especially in the field of unmanned aerial vehicles. A study on this is due to be presented in late 2011.

### **ECTRI – European Conference of Transport Research Institutes**

At the end of January 2011 Dr. Piehler, DLR Programme Director for Transport, assumed the presidency of ECTRI. He was unanimously elected to the two-year post at the plenary meeting in November 2010. Currently representing the interests of 28 leading European transport research institutes with a multi-modal focus, ECTRI is actively involved in shaping the European research area. For example, its own position paper was submitted in advance of the publication of the European Commission's green paper on the next FRP and the Strategic Transport Technology Plan (STTP). Together with ACARE and EREA, ECTRI was also invited by the Commission to participate in a related hearing.

### **AET – Association for European Transport**

DLR has been a member of AET since the beginning of 2011. AET is one of the leading European organisations in the transport sector and with more than 350 members from 35 countries has a broad network in research, business and administration. In addition to the benefits of an extended network, AET membership is attractive to DLR by enabling it to play an active role in Europe's leading transportation conference (ETC) and AET's special interest groups by participating in relevant committees.

### **ETRR – European Transport Research Review**

As Chairman of the Advisory Board, the Programme Director for Transport makes a considerable contribution to the strategic direction of the ETRR open access journal. Under his management an evaluation took place in mid-2010. The objectives were to review the ETRR's development to date in terms of quality, the effectiveness and efficiency of processes, structural suitability and financial sustainability. Twelve assessors performed an in-depth examination of this extensive range of issues and the suggestions for improvements put forward by the editor-in-chief and Chairman of the Advisory Board. The response was extremely positive with a strongly upbeat view of the journal's future. DLR also continues to be involved in the ETRR's positive performance on the operational level of associate editor and on the editorial board and its growing acceptance within the transport community.

### **EERA – European Energy Research Alliance**

Along similar lines to EREA in aviation and ECTRI in surface transportation, EERA (European Energy Research Alliance) is also preparing its own positions in readiness for the next Framework Programme. The focus here is mainly on establishing joint programmes that allow national energy research facilities to combine resources and therefore to help implement the Strategic Energy Technology Plan (SET-Plan). EERA's setup as a non-profit organisation in accordance with Belgian law is being checked.

### **IFAR – International Forum for Aviation Research**

IFAR is a new international body that connects and represents aerospace research organisations. Formed in 2010 on DLR's initiative, IFAR brings together up to now leading aeronautical research organisations from 21 countries to address climate and environment challenges faced by the air transport community worldwide. Prof. Szodruich, a former member of the DLR Executive Board, chairs the forum. DLR is in charge of climate issues and administers the office.

### **N.ERGHY – New European Research Grouping on Fuel Cells and Hydrogen**

As a member of the Executive Board of N.ERGHY, the European association of research facilities within the Fuel Cells and Hydrogen Joint Technology Initiative (FCH-JTI), DLR is significantly involved in the organisation and strategic direction of the grouping. The aim of the initiative is to accelerate the deployment of technologies on international markets. To achieve this goal, the fourth call for proposals for FCH-JTI projects is being held this year already with a total budget of 109 million euros. At the moment a key focus is consolidating and furthering initiatives around involvement in the upcoming European Union Framework Programme.

### **Collaboration with NLR**

At the meeting of the DLR-NLR Joint Executive Board on 21 December 2010 the future development of the joint subsidiary AT-One was discussed and approved. At the same meeting a joint appearance at the ATC Global show in Amsterdam was confirmed. Ongoing programme cooperation outside air traffic management research was analysed and potential new joint topics were discussed, especially in the area of European research infrastructure.

Following very lengthy preparations, the SESAR Joint Undertaking (SJU) published the call for proposals for associated members within the SJU in February 2011. DLR and NLR applied as a consortium under the name AT-One in five of the six advertised areas and were successful in three. The consortium has thereby achieved the status of associated partner in SESAR.

AT-One was also actively involved in the 9th USA/EUROPE Air Traffic Management R&D Seminar arranged by Eurocontrol and FAA.

#### **Collaboration with ONERA**

To strengthen in particular exchanges between younger scientists between the two institutions, a workshop for up-and-coming scientists was organised in Meudon on 16 July 2010. The seminar was well attended by 25 participants (DLR 11, ONERA 14). The aim of the first meeting placed less emphasis on scientific discussion and more on getting to know each other and building networks, as well as a brainstorming session on improving exchanges of staff. A return visit by ONERA scientists to DLR took place at the Braunschweig site on 15 October 2010.

From 9 to 11 February 2011, DLR and ONERA held the joint ONERA-DLR Aerospace Symposium (ODAS) in Toulouse. This year it was all about civil transport aircraft research to coincide with ten years of cooperation in the field of transport aircraft. Unusually the prize for best contribution to the symposium was awarded to two winners: Jana Ehlers from DLR and Myriam Kaminski from ONERA.

#### **Collaboration with CNES**

The Franco-German MERLIN Satellite to observe the methane content of the Earth's atmosphere using laser radar is based on a meeting between Parliamentary State Secretary Hintze and Minister Précresse. Collaborative work commenced

in France and Germany in May 2010 on the detailed definition of a MERLIN mission concept (mission phase 0). The established project teams at the two space agencies, CNES and DLR, are working together very successfully and coordinate their activities regularly. German contributions to MERLIN are worked on by a consortium headed by Astrium GmbH in Ottobrunn as part of an industry project. On the French side, work is being performed by CNES Toulouse without any significant industrial involvement. A mission concept has been drawn up over the past year. In deviation from political guidance, 2016/17 is being viewed as a realistic timeframe for launching the satellite. Because the estimated costs were significantly higher than the funding requirement originally budgeted for, the satellite's scientific mission requirements were reduced and the instrument technically simplified to save money. The Steering Committee gave its approval of further technical feasibility in July 2011. Mission phase A is expected to be completed by May 2012.

The governments of France and Germany agreed at their joint summit in February 2010 to establish a DLR/CNES working group on launchers. The task was to debate a new generation of European launch vehicles and prospects as well as to create and evaluate possible long-term scenarios in the European launcher sector. The working group's findings were to be presented by the end of 2010.

The DLR/CNES working group was successful and activities were completed on schedule. Results were presented to the two governments at the Franco-German summit on 10 December 2010. Both sides reasserted their interest in redeploying the working group in preparation for the Ministerial Council conference in 2012.

In the field of launcher technology there are also regular exchanges between experts at CNES and DLR institutes which are to be stepped up.



Left: Signing the DLR/ASAL MoU in Cologne on 8 February 2011; Dr. A. Oussedik (Director of ASAL), General F. Zerhouni (President of the ASAL Supervisory Board), Prof. Wörner, Dr. Reile (left to right)



Center: Australian minister Kim Carr (right) and Prof. Wagner signing the MoU on joint research into concentrating solar technology



Right: Brazilian delegation visit: bilateral meeting between Dr. Densing, DLR (third from left) and Dr. Carlos Ganem, AEB President (fourth from left)

## International Collaboration

### Algeria

In early February, a high-ranking delegation from the Algerian Space Agency ASAL (Agence Spatiale Algérienne) headed by its director Dr. Azzedine Oussedik visited DLR sites in Bremen, Bonn, Cologne and Oberpfaffenhofen over the course of three days. The guests from North Africa gained in-depth insights into space flight research at DLR and met with representatives of German aerospace companies. A Memorandum of Understanding (MoU) was signed in Cologne on 8 February 2011 which now forms the basis for extending German-Algerian cooperation in space research. Rich in oil, gas and sunshine, the country already cooperates with DLR on energy research and has had a National Space Programme for some years. Two Earth observation satellites are already in operation with others at the planning stage. Ground control stations and research institutions are also gradually being expanded. The key objectives are improving communica-

tions, environmental protection and disaster preparedness and mitigation in the country which covers an area six times larger than Germany. The visit was highly successful and provided some specific approaches for collaborative projects, for example testing remote sensing systems.

### Australia

In March 2011 DLR and the Australian Solar Institute (ASI) signed an agreement in Berlin on cooperation in the field of concentrating solar technology. The signatories were the Australian Minister for Innovation, Industry, Science and Research, Senator Kim Carr, and member of the DLR Executive Board Prof. Ulrich Wagner. Australia has copious regions that are highly exposed to the sun, making them ideally for deploying a technology in which DLR has internationally recognised expertise.

### Brazil

In July 2010 Dr. Carlos Ganem, President of AEB – the Brazilian Space Agency, visited DLR for talks on bilateral cooperation particularly with regard to sounding rocket technology. After touring DLR sites in Oberpfaffenhofen and Lampoldshausen, Dr. Ganem held talks with DLR Space Administration on the subject of working together on research under space conditions. Brazil has for many years supplied reliable rocket motors that are essential to the TEXUS science programme as part



of the national programme and to ESA's high altitude research programmes. Long-term availability of the Brazilian contribution is of great value to German zero-gravity research. The visit set the course for expanding this collaboration.

A Brazilian delegation from DCTA (Department of Aerospace Science and Technology) also visited in March 2011 accompanied by the new AEB President Dr. Marco Antônio Raupp. There were plans to follow the launch of TEXUS 49 from the Kiruna launch site. Due to the launch being postponed at the last minute the experts had the opportunity to gain a deeper understanding of the technical facilities and the launch vehicle. A subsequent visit to Oberpfaffenhofen allowed detailed discussion of further collaboration, specifically developing engines for sounding rockets. Shortly afterwards, Dr. Thomas Reiter met with the Brazilian minister for research and technology, Dr. Aloizio Mercadante, for bilateral talks during the Hanover trade show. The partners value this long-standing relationship which has proved highly successful for both sides and resolved to continue supporting aerospace research activities.

### Japan

Collaboration with Japan was also extended further in 2010. A visit to Japan in October 2010 by Rainer Brüderle who was Minister of Economics at the time and accompanied by, among others, Prof. Wörner helped strengthen relationships. In Japan in particular, it is important to back up current projects that are going well on a scientific basis and contacts with high-profile visits.

In addition to space flight, DLR is working with Japan on many aeronautical projects. The annual trilateral meeting between JAXA, DLR and ONERA of

France took place in Tokyo in November 2010. At this meeting several active projects were extended and some new collaborative projects were discussed.

The massive earthquake and tsunami in Japan in March 2011 certainly represents a watershed moment for the aerospace sector in Japan. JAXA facilities were damaged and the high costs of reconstruction after the disaster are also impacting space and aeronautical research. The disaster has however demonstrated how effectively DLR works with its Japanese partner JAXA on disaster management. Due to close contacts between DLR and JAXA in the area of disaster monitoring and radar imaging, DLR was able to provide vital pictures to Japan very soon after the disaster to assist in addressing the situation. This collaboration is to be expanded further in future.

In the field of space flight it was possible to likewise extend the level of cooperation further despite the disaster. Of particular note here is the cooperation on the Japanese Hayabusa-2 asteroid mission. Following the successful Hayabusa-1 mission to an asteroid, which is well-known in Japan, DLR has the opportunity to participate in the Hayabusa-2 follow-on mission. Work is currently focused on supporting Japanese colleagues in the area of zero gravity testing. Depending on the financial feasibility, involvement in a small lander package is possible. This would move around on the asteroid and take important measurements.



Prof. Henke (left) and Dr. Ishikawa (JAXA, Executive Director for Aeronautics) after signing several cooperation agreements between DLR and JAXA in the field of aeronautics



New DLR satellite receiving station in Inuvik

### Canada

The key event in terms of DLR's working relationship with Canada was the inauguration of the DLR satellite receiving station in Inuvik in August 2010. The occasion was attended by Canadian representatives of various organisations such as the Canadian Space Agency (CSA), the Canada Center for Remote Sensing (CCRS) and a number of local organisations, as well as Chairman of the DLR Executive Board Prof. Wörner. At present, the DLR antenna is mainly used to receive data from TerraSAR-X and TanDEM-X. Over the medium and long-term the antenna will be the focus of greater cooperation with Canada in the field of Earth observation. In addition to bilateral projects with Canadian partners, joint participation in receiving data for ESA Earth observation missions is planned.

As well as the inauguration of the Inuvik satellite receiving station a number of meetings were held between DLR and its Canadian partner organisations. Visits took place in both Canada and Germany in a highly constructive atmosphere – a sign of the positive working relationship that exists with Canada.

### Kazakhstan

On 18 July 2010 there was an official meeting in Astana between Kazakhstan's President Nursultan Nazarbayev and Chancellor Merkel on her trip to Asia. Giving substance to the meeting, more than 40 agreements were signed between German and Kazakh institutions (commercial businesses, universities, research institutions, agencies) as part of

an economic forum between the two countries. At the request of Kazakhstan's government, the framework agreement between the German Aerospace Center and the National Space Agency of Kazakhstan (KazCosmos) covering collaboration on activities in the space sector was prepared for signing in Astana. Prof. Wörner signed the agreement together with Mr. Talgat Musabayev, the head of KazCosmos. During a dinner at the President's residence there was an opportunity to discuss aerospace themes personally with the President of Kazakhstan and the German Chancellor. Key areas of cooperation with Kazakhstan include Earth observation – specifically the search for raw materials, water management in Central Asia and monitoring agriculture – and technological support on designing and building microsattelites.

### Russia

12 April 2011 marked the 50th anniversary of a very special event: the first human flight in space made by Yuri Gagarin. The celebrations in Moscow were attended by a DLR delegation headed by Dr. Reiter who was awarded the Russian Space Exploration Service Medal for his special role in developing manned space flight. The medal was presented to him personally by the President of the Russian Federation, Mr. Medvedev. Others besides Dr. Reiter who received awards were the German astronauts Siegmund Jähn, Ulf Merbold, Klaus Dietrich Flade and Reinhold Ewald.

The DLR Institute of Robotics and Mechatronics (RMC) works closely with the Russian Institute of Robotics and Technical Cybernetics (RTC) in St. Petersburg. Of particular note this year was the recovery of the ROKVISS (Robotic Components Verification on the ISS) robotic arm from the ISS by RKK Energija. The experiment was installed on the ISS in 2004, disassembled in early 2011 and brought



Installing the ROKVISS experiment on the Swesda module of the ISS in January 2005

back to Earth. ROKVISS was funded from DLR Space Administration budget and implemented by Kayser-Threde GmbH and the Institute of Robotics and Mechatronics. At the end of the active research phase the hardware onboard the ISS became the property of Roscosmos and was passed by Roscosmos to RKK for further use. As part of the "Kontur" project, the robotic system is being disassembled and analysed at RMC together with specialists from RTC. The goal is to find reasons for the small changes in the robotic system's mechanical properties during its use in space. The robotic arm will then be overhauled and passed to RTC in working order for further use. The agreement on implementing this first phase was signed in 2011.

At ILA 2010 Prof. Wörner and Prof. Perminov, the former head of the Russian federal Space Agency Roscosmos, signed a framework agreement covering research under space conditions on the Russian Bion M1 and Photon M1 type returning satellites. In 2011 two agency agreements were negotiated – one on Bion M1 (biological experiments, payload approximately 25 kg, 30-day period of application, launch May 2012) and another concerning Photon M1 (material physics in space, 60-day period of application, launch 2013). The agreement on Bion M1 has already been signed. The probes for the respective experiments are shared and results made available to scientists on both sides in the same way.

### Singapore

In May Prof. Henke signed a MoU in Oberpfaffenhofen with Nanyang Technological University. The MoU provides a framework for future cooperation between the two facilities in the areas of Earth observation and its use in navigation, environmental monitoring and security, electromobility as well as maintenance, repair and overhaul in aeronautics.

### Thailand

On 2 May 2011 the first high-ranking delegation from GISTDA, the Thai space research organisation, visited DLR in Oberpfaffenhofen. There was a lively exchange between experts on the topics of Earth observation and disaster management. It was agreed to specify future areas of cooperation and to set them out in a MoU.

### USA

In terms of collaboration with NASA the signing of the DLR/NASA framework agreement at the DLR Christmas reception in December 2010 was of major importance. The framework agreement reinforces the excellent, close working relationship between the two organisations. The aim of the framework agreement is to promote bilateral collaborative projects between NASA and DLR (and other German research institutions funded by DLR) and to simplify administration. At the DLR Christmas reception there were also discussions with NASA on ongoing cooperations such as GRACE or the collaboration on the ISS, as well as potential



Signing the MoU with Nanyang Technological University (from left to right): Prof. Boey, Prof. Henke, Prof. Yong, Dr. Blumrich



NASA Administrator Charles F. Bolden (right) and Chairman of the DLR Executive Board Prof. Wörner (left) signing the framework agreement

future projects like Tandem-L, for example. Within the context of cooperation between DLR and NASA, the SOFIA (Stratospheric Observatory For Infrared Astronomy) research aircraft continues to be a noteworthy project. The first scientific data for this was delivered in December 2010, which constituted an important milestone.

In addition to space flight, cooperation with NASA in the field of aeronautics is very important to DLR. Future areas for cooperation were discussed at several meetings between Prof. Henke, the DLR board member responsible for Aeronautics research, and NASA Aeronautics Associate Administrator Dr. Shin. At other meetings new collaborative projects will be selected and promoted as appropriate. To date collaboration between DLR and NASA has focused on the areas of air traffic management (ATM), computational fluid dynamics (CFD), climate and aviation, and rotorcraft.

Within space and aeronautical research, meetings also took place between DLR and the National Oceanic and Atmospheric Administration (NOAA), the United States Geological Survey (USGS), the Federal Aviation Administration (FAA), various universities such as Purdue University, Penn State University, MIT and Berkeley, and most particularly the Air Force Research Laboratory (AFRL). There were several visits and workshops with AFRL in autumn of 2010 and spring 2011. Due to the high technical level and breadth of research, the cooperation with AFRL is of growing importance for DLR.

At the National Space Symposium in Colorado Springs in April 2011, DLR exhibited for the first time on selected topics relating to Earth observation and security research. Chairman of the DLR Executive Board Prof. Wörner took part in a high level panel discussion, explaining possible contributions that DLR could make to space exploration activities in the future.

Collaboration between DLR and the US National Renewable Energy Laboratory in energy research was recently put on an improved footing. In June 2011 DLR, Forschungszentrum Jülich (FZJ) and the Helmholtz-Zentrum Berlin (HZB) for Materials and Energy signed a cooperation agreement that is designed to significantly improve the framework for projects and scientist exchanges in the field of solar research. While FZJ and HZB focus on thin-film photovoltaics, DLR shares its unique competencies in the field of solar thermal power plants.

### **United Nations and international organisations**

As already mentioned, DLR joined the International Charter on Space and Major Disasters in October 2010.

With the help of DLR, German students were able to participate in the Space Generation Congress which was founded subsequent to UNISPACE III. This event took place in the run-up to the International Astronaut Congress (IAC) in Prague. With more than 100 other participants, they were able to rally in group projects on topics such as climate or exploration.

### **UN-SPIDER (United Nations Platform for Space-based Information for Disaster Management and Emergency Response)**

In Germany, the UN Office for Outer Space Affairs is represented in Bonn by the UN-SPIDER programme in which DLR plays a major role. SPIDER deals with space-based information for disaster prevention, mitigating their effects and managing the emergency response. In October 2010 therefore the annual workshop again convened, this time entitled. The 4C Challenge: Communication – Coordination – Cooperation – Capacity Development. Also in autumn 2010 two presentations took place at the German Mission to the United Nations in Vienna on the benefits of space-based support to disaster management. These presentations attracted a large and prestigious audience and highlighted what Germany and especially DLR do to provide assistance worldwide in the event of a disaster.



A presentation took place at UNESCO in Paris on the DLR/UNESCO collaboration for the protection of World Heritage Sites using satellite data. As at the previous year's event in Vienna, it was apparent that the DLR/UNESCO venture for the remote sensing of World Heritage Sites and biosphere reserves is excellently suited to raise the wider international public's awareness of the benefits of modern remote sensing satellites.

#### **UN-COPUOS (United Nations Committee on the Peaceful Uses of Outer Space)**

In spring of this year there were two reasons to celebrate at the United Nations: 50 years of manned space flight and 50 years of COPUOS. COPUOS was established as an ad hoc committee by the UN General Assembly in 1958, shortly after the successful launch of the first satellite. The Committee now has 70 members, making it the largest within the UN system. The main focus of the ceremony was the adoption of a declaration in which member states emphasised that space research and technology serve the whole of humankind. The lunchtime reception was hosted jointly by Ambassador Rüdiger Lüdeking, Germany's permanent representative to the United Nations in Vienna, and DLR Member of the Bundestag Klaus-Peter Willsch, acting president of the European Interparliamentary Space Conference, and Dr. Gerd Gruppe, the DLR board member responsible for Space Administration, used the occasion to highlight the importance of the German space sector. A special exhibition marking 50 years of manned space flight was organised to communicate fascination with space travel to a wide audience. The German stand showcased the TANDEM-X Earth observation mission and the planned German on-orbit servicing mission (DEOS) to repair or dispose of malfunctioning satellites.



UN-COPUOS function in Vienna (from left to right): Dr. Annette Fröhlich, Ambassador Rüdiger Lüdeking, member of the Bundestag Klaus-Peter Willsch and member of the DLR Executive Board Dr. Gerd Gruppe

#### **COSPAR**

The 38th Scientific Assembly of COSPAR (Committee on Space Research) was held in Bremen, Germany, from 18 to 25 July 2010. With a record number of approximately 4,400 abstracts submitted and over 3,500 attendees, this assembly was the biggest so far. As part of the opening activities, DLR held a round table to address space and global change issues. Those participating were Prof. Wörner (Chairman of the DLR Executive Board), Jean-Jacques Dordain (ESA Director General), Dr. Carlos Ganem (President of AEB, the Brazilian Space Agency), Dr. David Kendall (Director General Space Science and Technology, Canadian Space Agency), Dr. Barbara Ryan (Director WMO Space Programme, WMO), Prof. Berrien Moore III (Dean of the College of Atmospheric & Geographic Sciences, University of Oklahoma) and Ernst Rauch (Head of the Corporate Climate Centre, Munich Re). The discussion was attended by nearly 1,000 guests.

## Communications

DLR Communications is responsible for press communications, cross-media activities, fairs, exhibitions and other events as well as publications. It also ensures that DLR presents a consistent image to the public.

DLR's profile in relevant areas such as the media, Internet and at fairs and exhibitions was again very positive over the past year. This is reflected in its consistently neutral to positive media image as well as the high number of visits to the DLR website and strong interest in the organisation's fairs and events. As a result of working closely with DLR sites, institutes and facilities at all levels of communications, DLR is being perceived as a unified entity in its external presentation.

Communicating with the public via the DLR web portal is a key task. Editorial formats befitting modern scientific communication such as web news, reportage, interviews and webcasts with their high informational content continue to attract strong and growing interest. The DLR portal receives 350,000 visits monthly, generating on average more than 1.4 million page views.

Events associated with the ash cloud from Iceland's Eyjafjallajökull volcano in April 2010 and DLR's positive media performance here continued to have an effect into 2011. DLR's profile in the media improved strongly after April 2010 with DLR being in demand as an objective point of contact once again when Grimsvötn erupted in 2011. Experience garnered in April 2010 not only benefited DLR Communications when Wikileaks emerged in January 2011 and on the ROSAT issue in April 2011, a sustained, good media image also means that DLR continues to be presented positively in the public eye. This also includes that the transfer quality (media use of texts and statements) of press releases written and published by DLR Communications has increased to almost 70 per cent.

The over 70 fairs and exhibitions attended last year once again constituted a major challenge. Services range from organisational and logistical support for institutes and facilities through to making all preparations for and holding DLR's annual general meeting, overseeing event content and producing films.

## Political and Economic Relations

This DLR department is responsible for shaping relationships with the worlds of politics and business.

DLR is increasingly involved in discussions on formulating long-term policies that focus not just on classic aerospace topics but also strategic policy and social challenges of the future, especially issues relating to energy, mobility and security research. These issues all have high economic importance and wide-ranging influence on sustaining the social and natural systems that underpin the state and society in the longer term. Against this backdrop, DLR plays an increasingly important role in the thematic consultation processes of parliaments and government institutions at the federal and state level, in business and in the trade associations, as well as in activities at the international parliamentary level. The framework for the unit's activities focuses on the manifold requests for policy advice associated with political calls for sustainable policies.





Left: Politics meets research – DLR presents knowledge of tomorrow to European Commissioner Máire Geoghegan-Quinn (left) and minister for NRW Svenja Schulze (right) during an informational and working visit to DLR and ESA in Cologne

Center: Astronaut Doug Wheelock describing his experiences onboard the International Space Station to Kurt Beck, Minister President of Rhineland-Palatinate

Right: DLR's 16th parabolic flight campaign – Prof. Hans-Peter Keitel, President of the Federation of German Industries (BDI), experiences zero gravity onboard the Airbus 300 Zero-G; for him experiments in zero gravity are an important part of developing new products

A number of information discussions and special activities were carried out accordingly. Examples include:

- Fact-finding trips concerning DLR "products" and international space flight events for politicians and business leaders (parabolic flights, shuttles launches etc.)
- Thorough political consultation, for example on parliamentary budget procedures
- Strengthening regional networking by DLR headquarters by maintaining close contacts and through visits from, for example, the mayors of Bonn, Cologne and Siegburg, and expanding a regional network with the city of Aachen
- Boosting DLR's international involvement and networking in the political sphere through of visits from EU Commissioners and ministers to DLR (EU Commissioner for Research Geoghegan-Quinn, the North Rhine-Westphalia Minister for Science Schulze and visits by numerous regional members of the Bundestag)
- Implementing DLR topics in the political sphere through the use of prestigious testimonials such as ISS Commander D. Wheelock on information trips to among others the Minister President of the Rhineland-Palatinate
- Boosting DLR efforts for the Aerospace parliamentary group and its chairman MdB Willsch by holding parliamentary evening events, for example, such as celebrating the 25th anniversary of the D-1 mission with 400 representatives from the worlds of politics, business and industry, including Parliamentary State Secretary Hintze and top-level functionaries from leading European and German space agencies and industries
- Organising and carrying out a live broadcast to the International Space Station ISS as part of celebrations of German reunification with the Federal President and Dr. Thomas Reiter who was the DLR Executive Board member responsible for space at the time.





# People

## Gender Equality and Work-Life Balance

“The German Aerospace Center not only creates the same conditions for women and men to achieve professional success and does it better than others, it also supports women’s careers within the organisation, thereby boosting its attractiveness as an employer.” This was said when DLR was presented with the Total E-Quality award for the third time for its human resources policies focused on equal opportunities.

The Total E-Quality award recognises companies and institutions that implement equal opportunities in their HR and organisational policies where the focus is on employees and with the goal of fulfilling the potential of employees, irrespective of their gender.

Since 2002, DLR has also held work and family audit certification for its family-friendly human resources policies. The “**audit berufundfamilie**” is an ongoing process in which specific goals and activities are developed in various action areas. Having been certified for some years now, DLR is in a period of consolidation. As well as developing new activities, this primarily involves embedding existing activities at the forefront of the organisation in order to establish a lasting family-oriented corporate culture.

An employee survey on the balance between work and family life at DLR showed that DLR is on the right track in terms of its efforts to support work life balance. Flexible working models in particular meet with widespread approval.

A family-friendly working environment is crucial if a balance is to be founded between family life and careers. This insight forms the basis of the “Erfolgsfaktor Familie” (Success Factor Family) business programme initiated by the Federal Ministry of Family Affairs which now has more than 3,000 corporate and institutional members. DLR’s membership is a clear indication of its commitment to family-friendly practices, recognising their role as a key element in successful corporate governance.

Support for employees seeking suitable care provision for children or other dependants was extended further through the family counselling service: in addition to a contract with a new external service provider offering assistance in this area, DLR added more places at daycare centers for children under age three. Contracts are now in place in Braunschweig, Göttingen and Berlin, as well as for the sites in Cologne and Bremen.



## Human Resources Development

For several years now there has been a steady increase in demand for qualification and promotion measures in human resources development based on need. There was again a 20 per cent rise in the level of take-up for in-house training programmes in 2010 compared to the previous year: In total, 561 basic and further training events in all were held for employees, managers and management trainees. The dropout rate from training programmes was also reduced further (17 per cent in 2010).

The number of team workshops (events tailored to specific organisational units) was significantly increased from 68 (2009) to 125. This underlines the acceptance of human resources developers achieved among internal customers at both management and other levels and the increasingly close relationship between the development of personnel and that of the organisation.

In addition 11 mentoring pairs were put together in an extensive new selection process and supervised by high-ranking managers and members of the Executive Board in a one-year mentoring relationship containing new programme elements.

63 per cent of employees participated at least once during 2010 in training programmes, personnel development opportunities for management or in team workshops. On average 2.2 days per year per employee were spent on personnel development activities (re-training events or team workshops).

Promoting talented young scientists is a key goal of human resources development. For the seventh time, a moderated forum was held between up-and-coming management talents and the Executive Board of DLR with a revised format. More than 70 potential candi-

Personnel	2008	2009	2010
Employees	5,880	6,485	6,832
Scientific associates (total)	3,295	3,677	3,913
Scientific associates engaged by institutes and facilities		3,076	3,140
Permanent/fixed-term contracts	3,148/2,732	3,229/3,256	3,313/3,519
Proportion of women			
- total	30%	30%	30%
- in management positions	14%	14%	14%
- scientific associates	16%	17%	13%
Young scientists	86	63	55
Doctoral candidates (internal/external)	670	734	763
Trainees	252	252	247

dates were able to discuss with the highest management levels and learn about major strategic developments and decisions. This overcomes hierarchical barriers, promoting corporate identity.

The DLR\_Graduate\_Program received a positive response in the year after being launched: rising steadily to over 240 participants, the programme exceeded DLR's expectations and proved exceptionally popular. Some 90 training courses and workshops have so far been held within the framework of the cross-institute qualification programme. These events are continually evaluated and refined as appropriate. The DLR\_Graduate\_Program covers essential methodological, management and social skills which are useful in writing PhD theses efficiently, engaging in scientific activity within DLR, as well as during subsequent careers. Participation in the three-year programme is open to all DLR employees doing a doctorate. One of the highlights of 2010 was the DLR symposium for PhD students in Oberpfaffenhofen. A network of doctoral students was established as

part of this symposium with the aim of actively sharing ideas and experiences between institutes and sites. Since 2010 attendees also have the opportunity to network virtually via a database of abstracts.

Project management is a key competence of DLR employees. Use of the four-day intensive training course remained constant in 2010 with 95 participants.

HR development and mobility	2008	2009	2010
Training days per employee	1.8	2.1	2.2
Mentoring pairs	8	8	11
Assignments abroad (months)	545	487	531

A pleasing development was the sharp rise in interest in specific training events to prepare for PMP® certification, the world's most widespread and accepted qualification in Project Management. In 2010 21 employees took this opportunity.

A special project sees a separate projects career path – comparable to the management career path – being created to establish an interdisciplinary project manager job profile. With the project concept now having been developed and organisational preparations made,

this project is currently about to be piloted at three institutes benefiting between 60 and 80 members of staff. In addition to putting Project Management on a professional footing in terms of achieving scientific and commercial success, this pursues important objectives towards promoting new talent over the long term. The projects career path will open up opportunities for those in key roles and demonstrating a high level of potential, helping to retain their skills within DLR. Where hierarchies are flat in particular this generates necessary developmental and career prospects. At the same time, the associated qualification boosts the external employability of the next generation.

## Human Resources Marketing

The activities of the central human resources marketing department address three lines of action: (i) internal communication and implementation of the employer brand, (ii) boosting recognition of DLR as an attractive employer and (iii) supporting institutes and facilities on recruitment.

Implementation of the employer brand internally was continued. A series of workshops also familiarised everyone from human resources fully with related content and enabled appropriate activities to be derived.

Work continued on DLR's external image as an employer. The aim is for all redesigned materials to start being largely deployed at the same time.

Numerous contributions at events targeting relevant groups help raise DLR's profile as an attractive employer: Ideally this continues to be in the form of editorials in which employees talk first-hand about unique projects and positive experiences working for DLR. During the reporting period DLR attended a total of 11 higher education fairs and in April 2011 had a careers stand at a major industry trade show in Hanover for the first time. The tour of Germany's technical universities to promote ESA carried out with representatives of the German Aerospace Industries Association (BDLI) and ESA was continued, providing students with an exclusive setting to find out about different ways of joining DLR.

These activities were complemented by developing different event formats to be held at the various DLR sites in the future in order to inspire students to consider careers with DLR.

Preparations were completed for (trial) cooperation with a selected online job portal commencing in mid-August. Work was also started on a conceptual basis for DLR-specific human resources marketing metrics incorporating all suitable internal and external sources.



## German Staff at ESA

GTP, the German Trainee Programme between DLR and ESA, is a new tool for German human resources development within an international organisation. This programme supports young German academics as they take up employment at the European Space Agency and helps with their career options. Its purpose in the medium and long-term is to boost the share of German staff at ESA and to implement the mission of the German government and Bundestag to increase the proportion of German personnel within international organisations. GTP receives funding from BMWi and is financed under the National Space Programme. For programme purposes, GTP reports to DLR's Management office. The programme is managed by the trans-departmental DLR working group, which was set up for ESA's own recruiting purposes.

GTP enables approximately 10 trainees annually to undergo on-the-job training for up to two years in activity and programme areas within ESA that are a priority for Germany. They work in teams with colleagues and tutors from other ESA member states predominantly in engineering and scientific fields at ESA sites in the Netherlands, Italy, Germany, France and Spain.

German staff at ESA – a comparison

Member state	Number of employees	Employees [%]	Financial contribution [%]
Germany	435	19.3	23.9
France	529	23.5	19.5
Italy	401	17.8	14.2
GB	231	10.3	10.6
Spain	182	8.1	6.9

Only 25% of the participation in the launcher programme is taken into account for the calculation of the respective financing contributions.

At the end of 2010 the picture was as follows: ESA retained 2,249 employees in the salary brackets commensurate with high-level employment. By comparison with the previous year, the number of employees overall – including from Germany – had increased. For France, there was a slight downward trend.

Germany's under-representation in terms of the proportion of German personnel in relation to its financial contribution has improved somewhat and shows that measures such as the advisory service or the secondment programme agreed with ESA are gradually having an impact.

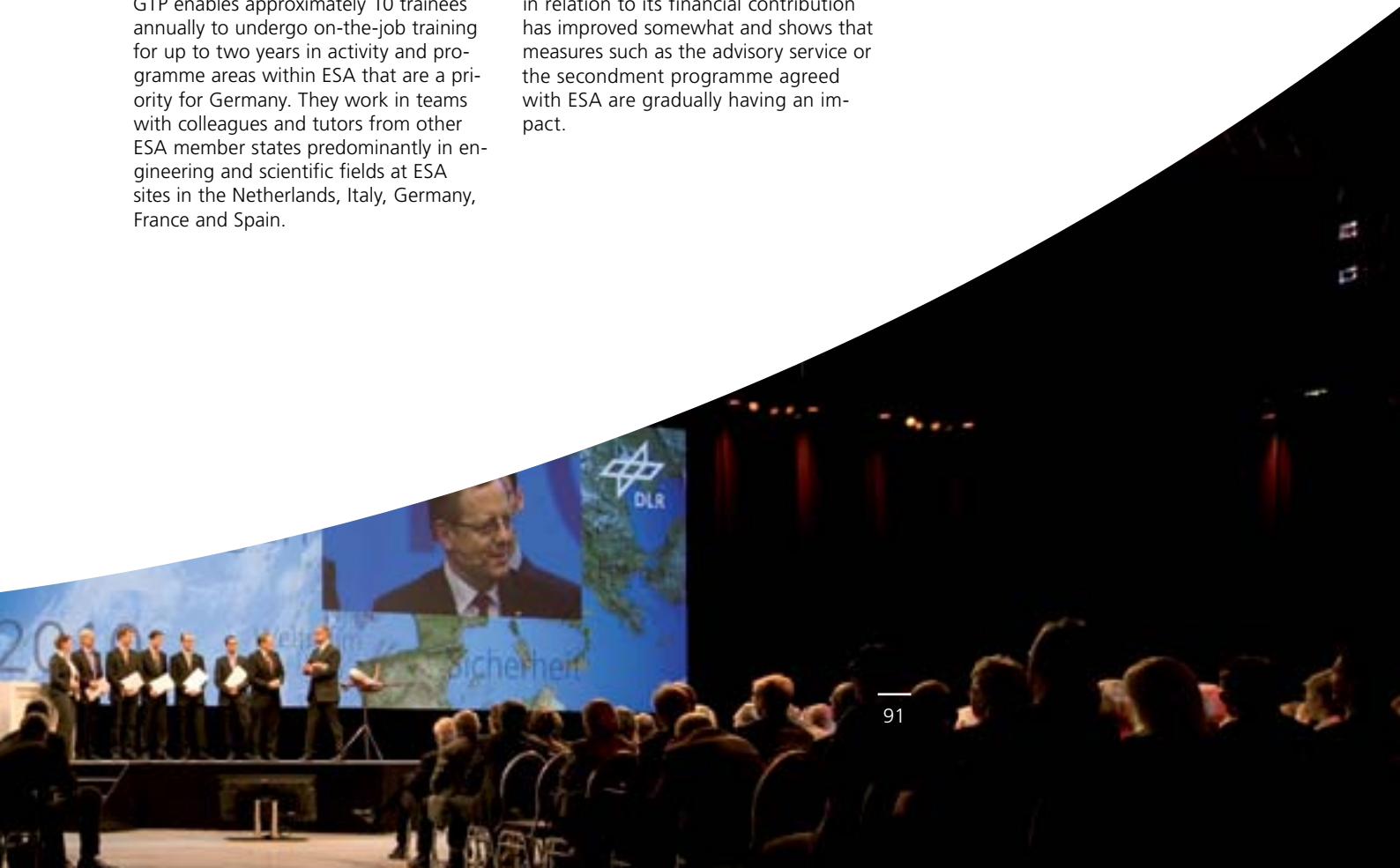



# Commendations and Awards

Each year DLR awards various prizes and honours to its employees. These prizes cover a broad spectrum rewarding both young and senior scientists as well as external research stays and prizes from institutions that wish to support DLR.

This year's winners in the various categories are listed below.

## Internal Commendations 2010

### **DLR Science Prize**

- Isaac Boxx Ph.D.  
Dr. Michael Stöhr  
Institute of Combustion Technology
- Dr. Reinold Braun  
Dr. Maik Fröhlich  
Andrea Ebach-Stahl  
Institute of Materials Research
- Dr. Nicolas Gebert  
Microwaves and Radar Institute

### **DLR Senior Scientists**

- Adj. Prof. Jürgen Horbach  
Institute of Materials Physics in Space
- Adj. Prof. Ruth Hemmersbach  
Institute of Aerospace Medicine

### **DLR Research Semester**

- Dr. Anko Börner  
Institute of Robotics and Mechatronics
- Susanne Gebhard  
Institute of Materials Research
- Dr. Dirk Giggenbach  
Institute of Communications and Navigation
- Claus Heuwinkel  
Institute of Propulsion Technology
- Dr. Rainer Schnell  
Institute of Propulsion Technology
- Dr. Arne Seitz  
Institute of Aerodynamics and Flow Technology
- Prof. Helmut Süß  
Microwaves and Radar Institute



**DLR Quality Prize**

- Katja Rosenthal, quality representative for the Institute of Flight Guidance in Braunschweig
- Dr. Rolf-Dieter Fischer, head of Technology Marketing and site manager for Cologne and Bonn
- Silvia Offermann, EFQM representative for Administrative Infrastructure

**Prizes awarded by the Society of Friends of DLR (SoF)**

- Otto Lilienthal Research Semester
- Prof. Lars Enghardt  
Research goal: new approaches in the field of turbomachinery broadband noise
- Fritz Rudolf Prize
- Robert Borrmann and Steffen Bäsig  
Launching the ATI organisational development project
  - Rolf Werninghaus  
Project manager on various major projects in the field of Earth observation
- Innovation Prize
- Team comprising Dr. Christian Sattler, Dr. Christian Jung and Dr. Ralf Olwig working on the solar water treatment plant project for DLR Lampoldshausen
- Hugo Denkmeier Prize
- Dr. David Rival  
(youngest doctoral candidate)  
Subject: Development, Control and Recovery of Leading- and Trailing-Edge Vortices in Tandem-Airfoil Configurations
- Chairman's Prize
- Andreas Baumann (youngest patent applicant), subject: device for docking to a satellite

**Selection of external awards in 2010**

Award	Prize winner
E.ON Research Award	Wolf-Dieter Steinmann
Albrecht-Ludwig Berblinger Prize	Dr. Mathias Basner
Amelia Earhart Prize Zonta Club Braunschweig	Kerstin Claudie Huber
2010 OWL Transfer Prize	Dr. Hans Peter Monner and M. Pohl
European Satellite Navigation Competition 2010; GNSS Living Lab Prize	Dr. Volker Tank et al.
Research Award, Alexander von Humboldt Foundation	Prof. Jeffrey Trinkle
State medal, Bavarian Ministry of Economics	Prof. Gerd Hirzinger
Honorary Research Associate, Victoria University of Wellington	Adj. Prof. Martin Schmücker
Karl Doetsch Young Scientist Prize	Jona Siebert

- School\_Lab Prize
- 2010 advanced physics class (Abitur) at the Martin-Butzer-Gymnasium Dierdorf for their project on capacitors in zero gravity – the behaviour of two capacitor plates in zero gravity
- Funded prize: Franz-Xaver Erlacher Prize to promote young scientists
- Dennis Stich, Institute of Atmospheric Physics, Oberpfaffenhofen





# FACTS & FIGURES

# Members and Committees

As of 30.06.2011, DLR had 46 sponsoring members in addition to honorary members, scientific members, and ex officio members.

## Ex Officio Members

- Prof. Manfred Aigner, Stuttgart
- Dr. Reinhold Busen, Oberpfaffenhofen
- Uwe Baust, Düsseldorf
- Jürgen Breitkopf, Munich
- Prof. Hans-Jörg Bullinger, Munich
- Bernhard Conrad, Hamburg
- Marco R. Fuchs, Bremen
- Prof. Ursula Gather, Dortmund
- Rainer Götting, Heidelberg
- Prof. Michael Grewing, France
- Dr. Gerd Gruppe, Bonn
- Prof. Peter Gruss, Munich
- Klaus Hamacher, Cologne
- Prof. Rolf Henke, Cologne
- Prof. Gerd Jäger, Essen
- Prof. Matthias Kleiner, Bonn
- Prof. Jürgen Klenner, Bremen
- Prof. Uwe Klingauf, Darmstadt
- Dr. Reinhold Lutz, North America
- Dr. Rainer Martens, Munich
- Peter-Michael Nast, Stuttgart
- Prof. Christiane Schmallius, Jena
- Prof. Stephan Staudacher, Stuttgart
- Prof. Ulrich Wagner, Cologne
- Dr. Gerardo Walle, Überlingen
- Prof. Johann-Dietrich Wörner, Cologne
- Prof. Gunter Zimmermeyer, Berlin

## Sponsoring Members

**(Public entities that regularly give at least Euro 50,000 annually)**

- Federal Republic of Germany, represented by the Federal Minister of Economics and Technology, Berlin
- State of Baden-Württemberg, represented by the Baden-Württemberg Minister of Finance and Economics, Stuttgart
- The Free State of Bavaria, represented by the Bavarian State Minister of Economic Affairs, Infrastructure, Transport and Technology, Munich
- State of Berlin, represented by the Senator for Education, Science and Research for the State of Berlin, Berlin
- State of Bremen, represented by the Senator for Education and Science, Bremen
- State of Lower Saxony, represented by the Lower Saxony Minister for Science and Culture, Hanover
- State of North Rhine-Westphalia, represented by the Minister for Innovation, Science, Research and Technology for the State of North Rhine-Westphalia, Düsseldorf

**(Natural persons, legal persons, societies and associations with no legal capacity)**

- Aerodata AG, Braunschweig
- AIR LIQUIDE Deutschland GmbH, Düsseldorf
- ALSTOM Power Systems GmbH, Mannheim
- AOPA-Germany, Verband der Allgemeinen Luftfahrt e. V., Egelsbach
- Arbeitsgemeinschaft Deutscher Verkehrsflughäfen (ADV, German Airports Association), Berlin
- Robert Bosch GmbH, Berlin
- BP Europa SE, Hamburg



- Bundesverband der Deutschen Luft- und Raumfahrtindustrie e. V. (BDLI, German Aerospace Industries Association), Berlin
- CAE Elektronik GmbH, Stolberg
- CAM Systems GmbH, Munich
- Carl-Cranz-Gesellschaft e. V., Wessling/Obb.
- Commerzbank AG, Großkundencenter Region West, Düsseldorf
- Deutsche Gesellschaft für Luft- und Raumfahrt – Lilienthal Oberth e. V. (DGLR, German Society for Aeronautics and Astronautics), Bonn
- Deutsche Gesellschaft für Ortung und Navigation e. V. (DGON, German Institute of Navigation), Bonn
- DFS Deutsche Flugsicherung GmbH, Langen
- Diehl Aerospace GmbH, Überlingen
- Diehl Defence Holding GmbH, Überlingen
- Dornier GmbH, Friedrichshafen
- EADS Deutschland GmbH, Munich
- ESG Elektroniksystem und Logistik GmbH, Fürstenfeldbruck
- Fraport AG, Frankfurt/Main
- GAF AG, Munich
- Gemeinde Weßling (local authority), Wessling/Obb.
- HDI-Gerling Industrie Versicherungs AG, Hanover
- Industrieanlagen-Betriebsgesellschaft mbH (IABG), Ottobrunn
- Kayser-Threde GmbH, Munich
- KUKA Laboratories GmbH, Augsburg
- LIEBHERR-AEROSPACE LINDENBERG GmbH, Lindenberg
- Lufthansa Technik AG, Hamburg
- MST Aerospace GmbH, Cologne
- MT Aerospace AG, Augsburg
- MTU Aero Engines GmbH, Munich
- Nord-Micro Elektronik AG & Co. OHG, Frankfurt/Main

- OHB-System AG, space technology and environmental technology, Bremen
- RheinEnergie AG, Cologne
- Rheinmetall Defence Electronics GmbH, Bremen
- Röder Präzision GmbH, Egelsbach
- Rohde & Schwarz GmbH & Co. KG, Cologne
- Rolls-Royce Deutschland Ltd. & Co. KG, Dahlewitz
- RUAG Aerospace Deutschland GmbH, Wessling
- Siemens AG, Munich
- Snecma Groupe SAFRAN, France
- Stadt Braunschweig, Braunschweig
- Tesat-Spacecom GmbH & Co. KG, Backnang
- Volkswagen AG, Wolfsburg
- ZF Luftfahrttechnik GmbH, Calden

## Scientific Members

- Prof. Philipp Hartl, Munich
- Prof. Hans Hornung, Pasadena, California/USA
- Prof. Joachim E. Trümper, Garching

## Executive Board

**(As of 30.06.2011)**

- Prof. Johann-Dietrich Wörner (Chairman)
- Klaus Hamacher (Deputy Chairman)
- Prof. Rolf Henke
- Dr. Gerd Gruppe
- Prof. Ulrich Wagner

## Honorary Members

- The Honorable Daniel Saul Goldin, Washington
- Prof. Walter Kröll, Marburg
- Prof. Reimar Lüst, Hamburg
- Jean Sollier, Rueil-Malmaison, France
- Prof. Gerhard Zeidler, Stuttgart

## Senate

As of 30.06.2011 the following persons were members of the senate:

### From the scientific sector

- Prof. Manfred Aigner
- Prof. Hans-Jörg Bullinger ex officio
- Dr. Reinhold Busen
- Prof. Ursula Gather (Deputy Chairwoman)
- Prof. Michael Grewing
- Prof. Peter Gruss ex officio
- Prof. Matthias Kleiner ex officio
- Prof. Uwe Klingauf
- Peter-Michael Nast
- Prof. Christiane Schmallius
- Prof. Stephan Staudacher

### From the economics and industrial sector

- Uwe Baust
- Jürgen Breitkopf
- Bernhard Conrad
- Marco R. Fuchs (Deputy Chairman)
- Rainer Götting
- Prof. Gerd Jäger
- Prof. Jürgen Klenner
- Dr. Reinhold Lutz
- Dr. Rainer Martens
- Dr. Gerardo Walle
- Prof. Gunter Zimmermeyer

### From the State sector

- Under Secretary Erwin Bernhard
- Secretary of State Helmut Dockter
- Under Secretary Dr. Thomas Gerhardt
- VLR I Michael Häusler
- Secretary of State Jochen Homann (Chairman)
- Secretary of State Dr. Josef Lange
- Under Secretary Dr. Ronald Mertz
- Secretary of State Dr. Knut Nevermann
- Privy Counsellor Carl Othmer
- Ministerial Director Gerold Reichle
- Ulrich Schüller

### (without voting rights in 2011)

- Under Secretary Günther Leßnerkraus

## Senate Committee

As of 30.06.2011 the senate committee comprised six members from the scientific sector, six members from the economics and industrial sector, and six members from the state sector.

### From the scientific sector

- Dr. Martin Bruse
- Prof. Klaus Drechsler
- Prof. Ursula Gather (Chairwoman)
- Prof. Reinhard Niehuis
- Prof. Heinz Voggenreiter
- Prof. Gebhard Wulfhorst

### From the sector of economics and industry

- Christa Fuchs
- Prof. Jürgen Lehold
- Georg Rayczyk (Deputy Chairman)
- Dr. Artur Redeker
- Dr. Helmut Richter
- Berry Smutny

### From the State sector (with voting rights in 2011)

- Under Secretary Helge Engelhard
- Deputy Assistant Under Secretary Rainer Krug
- Senate Counsellor Bernd Lietzau
- Chief Deputy Assistant Under Secretary Peter Mendler
- Under Secretary Dr. Dietrich Nelle
- Josef Schiller

### (without voting rights in 2011)

- Dr. Walter Dörhage
- Deputy Assistant Under Secretary Ronald Else
- VLR I Michael Häusler
- Deputy Assistant Under Secretary Dr. Axel Kollatschny
- Deputy Assistant Under Secretary Dietmar Schneyer
- Deputy Assistant Under Secretary Dr. Ulrich Steger

## Space Committee

(As of 30.06.2011)

- Dr. Sven Halldorn  
Federal Ministry of Economics and Technology
- Under Secretary Dr. Dietrich Nelle  
Federal Ministry of Education and Research
- VLR I Michael Häusler  
Federal Foreign Office
- Under Secretary Dr. Werner Kloos  
Federal Ministry of Food, Agriculture and Consumer Protection
- Under Secretary Gerold Reichle  
Federal Ministry of Transport, Building and Urban Development
- Under Secretary Norbert Weber  
Federal Ministry of Defence
- Under Secretary Dr. Peter Müller  
Federal Ministry for the Environment, Nature Conservation and Nuclear Safety
- Under Secretary Dr. Gabriel Kühne  
Federal Ministry of Finance
- RegDir Frank Wetzel  
Industrial Policy, German Chancellery
- Ministerial Director Beate Lohmann  
Federal Ministry of the Interior

## Scientific and Technical Council

**Members of the Scientific-Technical Council (As of 30.06.2011)**

- Prof. Stefan Schleichriem  
Institute of Space Propulsion
- Prof. Felix Huber (Deputy Chairman)  
Space Operations and Astronaut Training
- Prof. Dirk Kügler  
Institute of Flight Guidance
- Prof. Andreas Dillmann  
Institute of Aerodynamics and Flow Technology
- Prof. Karsten Lemmer  
Institute of Transportation Systems
- Prof. Martin Wiedemann  
Institute of Composite Structures and Adaptive Systems
- Dr. Marina Braun-Unkhoff  
Institute of Combustion Technology
- Dr. Joachim Götz  
Institute of Flight Systems
- Frank Kocian  
Institute of Structures and Design
- Florian Piekert  
Institute of Flight Guidance
- Dr. Thomas Holzer-Popp (Chairman)  
German Remote Sensing Data Center
- Dr. Stephan Ulamec  
Space Operations and Astronaut Training

# Affiliates and Joint Ventures

## **DLR Joint Ventures Gesellschaft mit beschränkter Haftung (DLR Joint Ventures Limited Liability Company), Bonn**

100%

The purpose of this company is participation in European Economic Interest Groupings (EEIGs) within the framework of the statutory tasks of the German Aerospace Center. The company holds interests in the European Project Management Agency EDCTP-EEIG and AT-One EWIV, an enterprise founded in 2007 to support and organise the collaboration between DLR and NLR in the field of air traffic management.

## **DLR Gesellschaft für Raumfahrtanwendungen (GfR) mbH (DLR Institute of Space Applications), Wessling**

100%

The purpose of the company is the provision of services relating to space applications.

DLR GfR mbH, together with Italian company Telespazio S.p.A., has a 50% stake in the founding of spaceopal GmbH, based in Munich. The main function of the company - subject to the award of contract by ESA - is the management of operations of the European satellite navigation system Galileo, including the two control centers in Fucino (Italy) and Oberpfaffenhofen (Germany).

## **German-Dutch Wind Tunnels (DNW) Foundation, Noordoostpolder/ The Netherlands**

50%

DLR established this foundation as a non-profit organisation on an equal-share basis with its Dutch partner organisation, NLR. Its remit is to operate, maintain and continue to develop the foundation's own low-speed wind tunnel in Noordoostpolder, as well as wind tunnels owned by DLR and NLR.

📍 [www.dnw.aero](http://www.dnw.aero)

## **European Transonic Windtunnel GmbH (ETW) (European Transonic Wind Tunnels), Cologne**

31%

ETW, the European Transonic Wind Tunnel, built and operated by four nations, Germany, France, the United Kingdom and the Netherlands, is the most modern wind tunnel anywhere in the world. The ETW will be used to test and optimise new aircraft designs using scale models under realistic flight conditions. The knowledge gained will play a decisive role in the success of the aircraft project.

📍 [www.etw.de](http://www.etw.de)

## **TeleOp Gesellschaft mit beschränkter Haftung (TeleOp Limited Liability Company), Wessling**

25%

This company was founded in collaboration with T-Systems, EADS and LfA Förderbank Bavaria. Its remit is to conduct negotiations within the framework of the GALILEO project, as required to meet the objective of obtaining an interest in the construction and operation of the European satellite navigation programme, GALILEO.

📍 [www.teleop.de](http://www.teleop.de)



**Anwendungszentrum GmbH  
Oberpfaffenhofen, Wessling****25%**

The Incubation Center was established as a public-private partnership and received start-up funding until the end of 2009 from funds provided by High-Tech-Offensive Bavaria. Since the launch of this start-up and relocation incubator, which was initially funded by DLR alone, over fifty companies from the field of satellite navigation have either passed through its gates or settled permanently at the Oberpfaffenhofen site.

📍 [www.anwendungszentrum.de](http://www.anwendungszentrum.de)

**Europäische Akademie zur Erforschung von Folgen wissenschaftlich-technischer Entwicklungen (European Academy for Research on the Consequences of Scientific and Technological Advances) Bad Neuenahr-Ahrweiler GmbH,  
Bad Neuenahr-Ahrweiler****25%**

The European Academy deals with the scientific study and evaluation of the consequences of scientific and technological advances for individuals and society, as well as for the natural environment. The main focus is on the examination processes that are influenced by the natural and engineering sciences and medical disciplines. As an independent scientific institution, the European Academy pursues a dialogue with the world of economy, politics and society at large. The state of the Rhineland-Palatinate is also a shareholder.

📍 [www.europaesche-akademie-aw.de](http://www.europaesche-akademie-aw.de)

**ZFB Zentrum für Flugsimulation  
(Centre for Flight Simulation)  
Berlin GmbH, Berlin****16.67%**

The purpose of this company is to provide flight simulators, in particular for research and education purposes, for applied research in the fields of flight control and flight management, system simulation and manipulation, and associated areas of technology, instruction and training for aerospace engineers and training for flight crews.

📍 [www.zfb-berlin.de](http://www.zfb-berlin.de)

**WPX Faserkeramik GmbH  
(WPX Fibre Ceramics), Cologne****10%**

WPX Faserkeramik GmbH is a start-up company ensuing from the DLR Institute of Materials Research, which is built upon DLR expertise in structural materials. The purpose of the company is to provide product development, sales and service for the technical applications of WHIPOX – DLR technology.

📍 [www.whipox.com](http://www.whipox.com)

**DUALIS MedTech GmbH, Bernried****10%**

DUALIS MedTech develops, produces and markets novel medical implants for patients with severe heart conditions. The central product is the DUALIS-VAD implantable heart support system with the DUALIS-TET wireless energy transfer system. The technology is based upon technology from the Institute of Robotics and Mechatronics, DLR Oberpfaffenhofen.

📍 [www.dualis-medtech.de](http://www.dualis-medtech.de)

**Zentrum für Angewandte Luftfahrtforschung GmbH (Centre for Applied Aeronautics Research), Hamburg****10%**

The purpose of the company is to promote applied aeronautics research at the Hamburg site. The company is tasked with contributing to developing the research infrastructure, combining existing research skills, improving collaboration between the industrial sector, suppliers, large-scale research facilities and the scientific community and implementing a stronger national and international network.

📍 [www.zal-gmbh.de](http://www.zal-gmbh.de)

**Innovationszentrum für Mobilität und gesellschaftlichen Wandel (InnoZ) GmbH (Innovation Centre for Mobility and Demographic Change), Berlin****9.8%**

InnoZ researches the complex interactions at the interface between mobility and social change, developing innovative solutions to newly arisen challenges faced by players in the transport and infrastructure sector. To this end, InnoZ combines a wide range of interdisciplinary skills under one roof. Sociological, geographical and economic expertise has equal weight to the practical perspectives of the transport economy.

📍 [www.innoz.de](http://www.innoz.de)

**ZTG Zentrum für Telematik im Gesundheitswesen GmbH (Competence Centre for Healthcare Telematics), Krefeld****6%**

The aim of the competence center is to introduce, develop and disseminate modern information and communications technology within the healthcare sector. Major focus areas include the provision of unbiased advice and Project Management services for customers from industry and healthcare, implementing interoperable solutions to facilitate integrated provision and promoting of knowledge transfer between the healthcare sector, science, politics and the wider economy.

📍 [www.ztg-nrw.de](http://www.ztg-nrw.de)

# Compilation of Performance Indicators

<b>Third-party funding</b>	<b>2008</b>	<b>2009</b>	<b>2010</b>
Total third-party revenue	€ 308 m	€ 381 m	€ 401 m
Revenue growth in comparison to previous year, commercial revenue from domestic R&D activity	11%	12%	-6%
Proportion of revenue from third-party sources	51%	49%	54%
Proportion of revenue from foreign clients (volume of revenue)	21%	25%	24%
Success rate of EU proposals over the last three years (accepted/submitted)	46%	37%	36%
Revenue from EU funding	€ 19.7 m	€ 21.7 m	€ 22.6 m
Ratio of EU projects as coordinator vs. all projects	14%	22%	22%

<b>Research-related results</b>	<b>2008</b>	<b>2009</b>	<b>2010</b>
Publications in peer-reviewed journals	442	577	654
Peer-reviewed publications in proceedings, books etc.	593	460	563
Presentations for scientific conferences, workshops and lectures*	0.55	0.55	0.51
Appointments to universities	12	13	14
Lectureships	248	244	296
Diploma theses	384	396	487
PhD theses	94	105	85
Postdoctoral qualifications	2	4	1

\* per scientific associate engaged by the institutes and facilities

<b>Technology Marketing</b>	<b>2008</b>	<b>2009</b>	<b>2010</b>
Revenue from licenses	€ 3.9 m	€ 3.9 m	€ 4.2 m
Start-up companies	2	2	2
New in-house technology transfer projects	8	11	14
Investment in technology transfer projects	€ 3.5 m	€ 2.8 m	€ 4.0 m

<b>Management instruments</b>	<b>2008</b>	<b>2009</b>	<b>2010</b>
Total project work	72.8%	73.1%	73.5%
<b>Quality management</b>	<b>2008</b>	<b>2009</b>	<b>2010</b>
Existing certifications and accreditations	25	28	30
Number of DLR auditors	15	10	11
Implementation of audits	32%	38%	49%
<b>National and European networks</b>	<b>2008</b>	<b>2009</b>	<b>2010</b>
DFG participations	33	34	38
Sponsorship agreements	49	41	32
<b>International collaboration</b>	<b>2008</b>	<b>2009</b>	<b>2010</b>
International visiting scientists*	7.9%	3.3%	3.0%
* staying > 1 month referenced to scientific associates in institutes			
<b>Personnel</b>	<b>2008</b>	<b>2009</b>	<b>2010</b>
Employees	5,880	6,485	6,832
Scientific associates (total)	3,295	3,677	3,913
Scientific associates engaged by institutes and facilities		3,076	3,140
Permanent/fixed-term contracts	3,148/2,732	3,229/3,256	3,313/3,519
Proportion of women			
- total	30%	30%	30%
- in management positions	14%	14%	14%
- scientific associates	16%	17%	13%
<b>New talent</b>	<b>2008</b>	<b>2009</b>	<b>2010</b>
Young scientists	86	63	55
Doctoral candidates (internal/external)	670	734	763
Trainees	252	252	247
<b>HR development and mobility</b>	<b>2008</b>	<b>2009</b>	<b>2010</b>
Training days per employee	1.8	2.1	2.2
Mentoring pairs	8	8	11
Assignments abroad (months)	545	487	531

# Use of Funds

## Overall revenue 2010

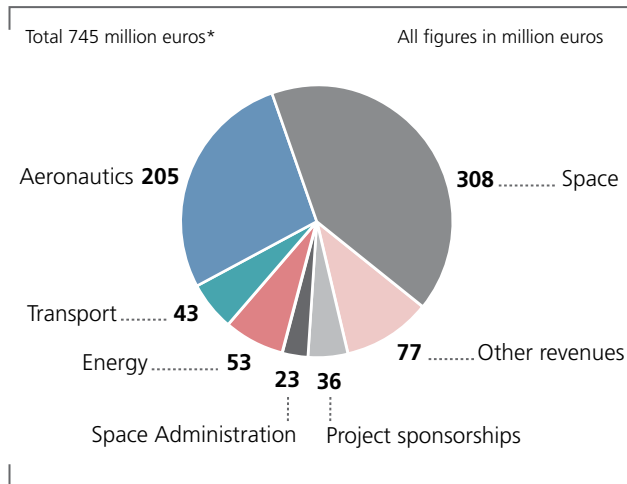

\* Economic stimulus package II in third party funding included

## Third-party funding related to origin 2010

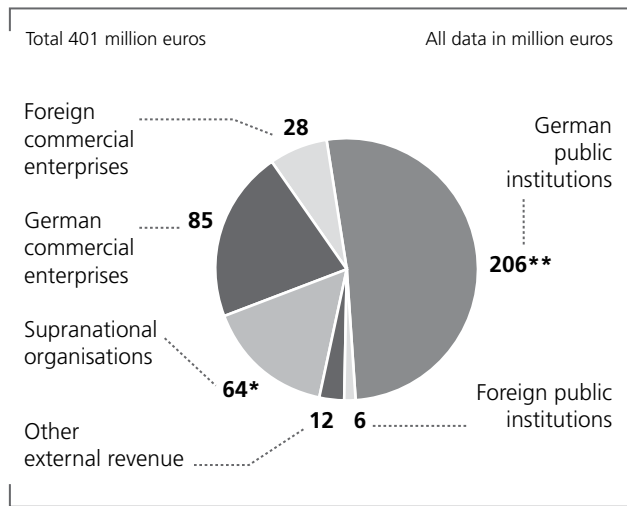

\* including: ESA 40, EU 23, other 1

\*\* including: national public institutions 125, project sponsorship 59, other r&B third-party funding 22

## Institutional Funding 2010\*

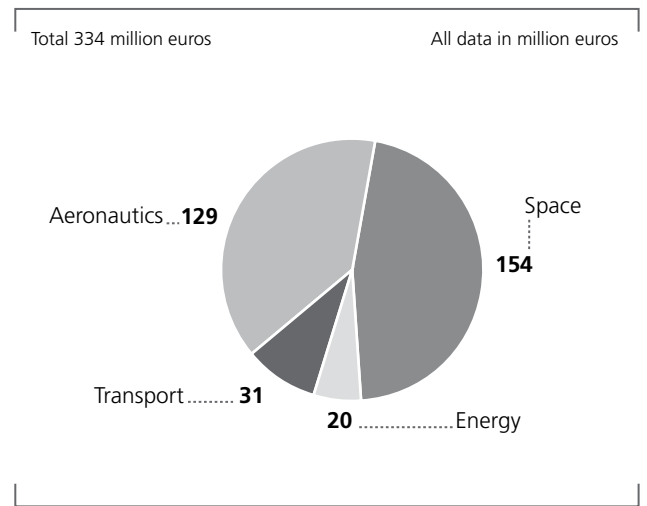

\* without other revenue



# List of Abbreviations

<b>ACARE</b>	Advisory Council for Aeronautical Research in Europe	<b>eROSITA</b>	extended ROentgen Survey with an Imaging Telescope Array	<b>Ma</b>	Mach
<b>AEB</b>	Agência Espacial Brasileira	<b>ESA</b>	European Space Agency	<b>MoU</b>	Memorandum of Understanding
<b>AFRL</b>	Air Force Research Laboratory	<b>ESCC</b>	European Space Components Coordination	<b>MRO</b>	Maintenance, Repair and Overhaul
<b>AI</b>	Administrative Infrastructure	<b>ESF</b>	European Science Foundation	<b>N.ERGHY</b>	New European Research Grouping on Fuel Cells and Hydrogen
<b>AIM</b>	Application Platform for Intelligent Mobility	<b>ESOC</b>	European Space Operations Centre	<b>NASA</b>	National Aeronautics and Space Administration
<b>AirTN</b>	Air Transport Net	<b>ESRIN</b>	European Space Research Institute	<b>NGT</b>	Next Generation Train
<b>ATI</b>	Administrative and Technical Infrastructure	<b>ESTEC</b>	European Space Research and Technology Centre	<b>NLF</b>	Natural Laminar Flow
<b>ATM</b>	Air Traffic Management	<b>ETW</b>	European Transonic Windtunnel GmbH	<b>NLR</b>	Nationaal Lucht- en Ruimtevaartlaboratorium
<b>ATRA</b>	Advanced Technology Research Aircraft	<b>EU</b>	European Union	<b>NOAA</b>	National Oceanic and Atmospheric Administration
<b>AutoOpti</b>	Automatic Optimizer	<b>EUREKA</b>	European Research Coordination Agency	<b>NREL</b>	National Renewable Energy Laboratory
<b>BMBF</b>	Federal Ministry of Education and Research	<b>FAA</b>	Federal Aviation Administration	<b>ONERA</b>	Office National d'Études et de Recherches Aéropatiales
<b>BMVBS</b>	Federal Ministry of Transport, Building and Urban Development	<b>R&amp;T</b>	Research and Technology	<b>HR</b>	Human Resources
<b>BMVg</b>	Federal Ministry of Defence	<b>FCH-JTI</b>	Fuel Cell and Hydrogen Joint Technology Initiative	<b>PMP</b>	Project Management Professional
<b>BMWi</b>	Federal Ministry of Economics and Technology	<b>FM</b>	Facility Management	<b>PT-DLR</b>	DLR Project Management Agency
<b>BOS</b>	Behörden und Organisationen mit Sicherheitsaufgaben (authorities and organisations responsible for security)	<b>FHS</b>	Flying Helicopter Simulator	<b>PT-LF</b>	Project Management Agency for Aeronautics Research
<b>C<sup>2</sup>A<sup>2</sup>S<sup>2</sup>E</b>	Center for Computer Applications in AeroSpace Science and Engineering	<b>GATE</b>	Galileo test and development environment	<b>QM</b>	Quality Management
<b>CAE</b>	Chinese Aeronautical Establishment	<b>Gfr</b>	Gesellschaft für Raumfahrt-anwendungen (DLR Institute of Space Applications)	<b>RMC</b>	DLR Robotics and Mechatronics Center
<b>CATS</b>	Climate-compatible Air Transport System	<b>GIS</b>	Geographic information system	<b>ROSCOSMOS</b>	Russian Federal Space Agency
<b>CCRS</b>	Canada Centre for Remote Sensing	<b>GMES</b>	Global Monitoring for Environment and Security	<b>RWTH</b>	RWTH Aachen University
<b>CFD</b>	Computational Fluid Dynamics	<b>GPS</b>	Global Positioning System	<b>SAR</b>	Synthetic Aperture Radar
<b>CFRP</b>	Carbon fibre reinforced plastic	<b>GQA</b>	Gesellschaft für Qualität im Arbeitsschutz (Society for Quality in Occupational Safety and Health)	<b>SES</b>	Single European Sky
<b>CIRA</b>	Centro Italiano Ricerche Aerospaziali	<b>GTP</b>	German Trainee Programme	<b>SESAR</b>	Single European Sky ATM Research
<b>CNES</b>	Centre National d'Études Spatiales	<b>SoF</b>	Society of Friends of DLR (GvF in German)	<b>SET-Plan</b>	Strategic Energy Technology Plan
<b>CoE</b>	Center of Excellence	<b>HGF</b>	Helmholtz Association of German Research Centers	<b>SHEFEX</b>	Sharp Edge Flight Experiment
<b>COPUOS</b>	United Nations Committee on the Peaceful Uses of Outer Space	<b>IABG</b>	Industrieanlagen-Betriebsgesellschaft (industrial plant operating company, a central analysis and testing organisation for the aeronautics industry)	<b>SOFIA</b>	Stratosphere Observatory for Infrared Astronomy
<b>COSPAR</b>	Committee on Space Research	<b>IAF</b>	International Astronautical Federation	<b>SOLHYCO</b>	Solar-Hybrid Power and Cogeneration Plants
<b>COST</b>	European Cooperation in Science and Technology	<b>IAQG</b>	International Aerospace Quality Group	<b>STTP</b>	Strategic Transport and Technology Plan
<b>CSA</b>	Canadian Space Agency	<b>IBMP</b>	Institute of Biomedical Problems	<b>TAMS</b>	Total Airport Management Suite
<b>CSP</b>	Concentrated Solar Power	<b>ICAO</b>	International Civil Aviation Organization	<b>TanDEM-X</b>	TerraSAR-X add-on for Digital Elevation Measurement
<b>DFG</b>	German Research Foundation	<b>iGREEN</b>	integrated Green Aircraft	<b>TEXUS</b>	Technological experiments under weightless conditions
<b>DFS</b>	Deutsche Flugsicherung (German air traffic control)	<b>ILA</b>	International aerospace exhibition	<b>TI</b>	Technical Infrastructure
<b>DGUV</b>	Deutsche Gesetzliche Unfallversicherung (German Social Accident Insurance)	<b>INS</b>	Innovation with Norms and Standards	<b>TRACE</b>	Turbo machinery Research Aerodynamic Computational Environment
<b>DIN</b>	German Institute for Standardisation	<b>INTA</b>	Instituto Nacional de Técnica Aeroespacial	<b>TWG</b>	Transsonic wind tunnel in Göttingen
<b>DLR</b>	German Aerospace Center	<b>ISO</b>	International Organization for Standardization	<b>UAV</b>	Unmanned Aerial Vehicle
<b>DNW</b>	German-Dutch Wind Tunnels	<b>JAXA</b>	Japan Aerospace Exploration Agency	<b>UNCCD</b>	United Nations Convention to Combat Desertification
<b>ECSS</b>	European Cooperation for Space Standardization	<b>JCM</b>	Joint Committee Meeting	<b>UNESCO</b>	United Nations Educational, Scientific and Cultural Organization
<b>ECTRI</b>	European Conference of Transport Research Institutes	<b>KazCosmos</b>	National Space Agency of the Republic of Kazakhstan	<b>UNOOSA</b>	United Nations Office for Outer Space Affairs
<b>EEE</b>	Electronic, electrical and electromagnetic components	<b>SME</b>	Small and medium-sized enterprises	<b>UN-SPIDER</b>	United Nations Platform for Space-based Information for Disaster Management and Emergency Response
<b>EERA</b>	European Energy Research Alliance	<b>CIP</b>	Continual improvement process	<b>VDSI</b>	Verband deutscher Sicherheitsingenieure e.V. (Association of German Safety Engineers)
<b>EFQM</b>	European Foundation for Quality Management	<b>LamAir</b>	Laminar Aircraft Research	<b>VECTOR</b>	Vehicle Technologies Scenario Model
<b>ERANet</b>	European Research Area Network	<b>LIDAR</b>	Light Detection and Ranging	<b>UN</b>	United Nations
<b>EREA</b>	Association of European Research Establishments in Aeronautics	<b>LuFO</b>	German Aeronautics Research Programme	<b>ZKI</b>	DLR Center for Satellite Based Crisis Information

## DLR at a glance

DLR is Germany's national research centre for aeronautics and space. Its extensive research and development work in Aeronautics, Space, Energy, Transport and Security is integrated into national and international cooperative ventures. As Germany's space agency, DLR has been given responsibility for the forward planning and the implementation of the German space programme by the German federal government as well as for the international representation of German interests. Furthermore, Germany's largest project management agency is also part of DLR.

Approximately 7000 people are employed at 16 locations in Germany: Cologne (headquarters), Augsburg, Berlin, Bonn, Braunschweig, Bremen, Goettingen, Hamburg, Juelich, Lampoldshausen, Neustrelitz, Oberpfaffenhofen, Stade, Stuttgart, Trauen, and Weilheim. DLR also operates offices in Brussels, Paris, and Washington D.C.

DLR's mission comprises the exploration of Earth and the Solar System, research for protecting the environment, for environment-friendly technologies, and for promoting mobility, communication, and security. DLR's research portfolio ranges from basic research to the development of tomorrow's products. In that way DLR contributes the scientific and technical know-how that it has gained to enhancing Germany's industrial and technological reputation. DLR operates large-scale research facilities for DLR's own projects and as a service provider for its clients and partners. It also promotes the next generation of scientists, provides competent advisory services to government, and is a driving force in the local regions of its field centres.



DLR

**Deutsches Zentrum  
für Luft- und Raumfahrt e.V.**

in der Helmholtz-Gemeinschaft

### **Strategy and International Relations**

Linder Höhe  
D-51147 Cologne

[www.DLR.de/en/](http://www.DLR.de/en/)